



INSTRUCTIONS & PARTS LIST FOR CASTLE TOOL SDG SERIES STRAIGHT DIE GRINDERS SERIAL "A"

Read and understand these instructions before operating this tool.



SAVE THESE INSTRUCTIONS!

⚠ WARNING	
	<p>When used improperly power tools can create hazardous situations.</p> <p>Everyone using, maintaining, changing accessories or working near this tool must read, understand and follow these Safety Instructions!</p> <p><i>Improperly used power tools can cause injury or death.</i></p>

DIE GRINDER SAFETY

- 

Die grinders can cause flying particles.
Proper eye protection must be worn at all times by tool user and bystanders.
Flying particles can cause eye injury.
- 

Power tools generate noise.
Ear protection must be worn when tool noise level exceeds 85 dBA. We also recommend that ear protection be worn when the tool noise level is below 85 dBA. See the tool's information sheet for the noise level.
Prolonged exposure to noise can cause hearing loss.
- 

Power tools vibrate.
Excessive vibration can cause injury. If numbness, tingling, pain or whitening of the skin occurs, stop using tool and consult a physician. See the tool's information sheet for the vibration level.
Prolonged exposure to vibration can cause injury.
- 

Rotating grinding wheels can cause cuts and abrasions.
Keep hands and other body parts away from grinding wheels to prevent cutting or pinching. Wear protective clothing and gloves to protect hands.
Contact with rotating grinding wheels can cause injury.
- 



Die grinders present a risk of entanglement.
Keep loose hair away from power tools and accessories. Keep hands away from moving parts of the tool and accessories. Do not wear jewelry, loose clothing, or neckwear around power tools. Keep work area clear of cleaning rags and all items that could become entangled with the tool.
Entanglements can cause injuries.
- 

Grinding operations creates dust.
Do not breathe grinding dust. Use approved mask.
Breathing grinding dust can cause injury.
- 

This tool is not insulated for contact with electric power sources.
Do not use near live electric circuits. When drilling into walls, be aware that they may have hidden electric wires.
Electric shock can cause injury.
- 

This tool is not intended for use in a flammable or explosive atmosphere.
Do not use this tool in a flammable or explosive atmosphere.
Explosions and fire can cause injury.
- 

Grinding metals creates sparks that can ignite flammable materials and vapors.
Only grind metals if the area is free of combustible or explosive materials or vapors.
Explosions and fire can cause injury.
- 

Grinding wheels that malfunction or spin off can cause injury.
Check the speed rating of the accessory or the speed printed on the wheel. This speed must be greater than the nameplate speed of the grinder and the actual speed of the grinder as measured with a tachometer. Do not exceed rated operating air pressure.
Exploding wheels can cause injury or death.
- 

Excessive overhang reduces the safe operating speed of mounted wheels, causes wheels to "whip", and shafts to bend.
When using die grinders, keep overhang to a minimum. Refer to enclosed "SAFETY GUIDE FOR SIOUX ABRASIVE WHEEL" for speed and overhang information.
"Whipping" wheels and bent shafts can cause injury.
- 

Die grinders can generate unexpected movement.
Keep a firm grip on the tool at all times. Be sure your body position allows you to have control of the tool at all times. Make sure your footing is secure. When possible, secure the work piece in a vice or with clamps.
Unexpected tool movement can cause injury.
- 

Using excessive force on a tool makes it hard to control.
Do not force tool.
Hard to control tool can cause injury.





Taping or wiring the throttle valve in the "ON" position will prevent the tool from shutting off if the tool should jam or malfunction or if anything unexpected happens.

Do not wire or tape down the "On-Off" valve of any power tool.

Tools that are prevented from shutting off can cause injury.



Poorly maintained and lubricated tools can fail unexpectedly.

Keep tool properly lubricated and in good repair at all times. Use only Sioux Air Motor Oil No. 288. See the tool's information sheet to find out what other greases and oils to use. Do not drop the end of the hose on the floor where it will pick up dirt and transport it into the tool. See information sheet for any additional maintenance requirements.

Unexpected tool failures can cause injury.



Damaged grinding wheels can explode.

Check the wheel for damage before mounting, such as chips and cracks. Handle wheels carefully to avoid dropping or bumping. Protect wheels from extremes of temperature and humidity. Check wheels immediately after any unusual occurrence that may damage wheels. Check wheels daily. Hold tool under bench or provide other protection when starting up a new wheel, a used wheel that has been remounted, or at the beginning of an operation. Run at operating speed in this protected area for at least one minute before applying to the work. No one shall stand in front of or in line with the wheel during this test.

Exploding wheels can cause serious injury or death.



Collets, nuts and related equipment in poor shape or not the proper ones for the wheel or tool used can cause wheels to malfunction. Grinding wheels not properly tightened can spin off.

Be certain that all collets, nuts and related equipment are in good shape, the proper ones for the type and size of wheel being used, and are securely fastened. Tighten collet securely. Match wheel or accessory shaft diameter to chuck or collet.

Grinding wheels that malfunction and spin off can cause injury.



Air hoses can come loose from power tools and whip.

Inspect and do not use tools with loose or damaged air hoses or fittings.

Whipping air hoses can cause injury.



Abnormal sounding or excessively vibrating grinders can indicate a hazard that could cause wheel to explode.

If the normal sound of the grinder changes, or if it vibrates excessively, shut it off immediately, remove the wheel, and check speed with tachometer. Tool could be overspeeding or the wheel could be damaged or not mounted properly.

Exploding wheels can cause injury or death.



Air hoses that are not oil resistant or are not rated for the working pressure can burst.

Make sure that all air hoses are oil resistant and rated for the working pressure.

Air hoses that burst can cause injury.



Tools not operated at proper air pressure can operate erratically.

Do not exceed a maximum air pressure of 90 psig/6.2 bar or as stated on the tool's nameplate or operating instructions. Use an air regulator to maintain proper air pressure.

Erratic operation in power tools can cause injury.



Improperly repaired tools perform unpredictably.

Repair tools at an Authorized Sioux Service Center.

Tools that perform unpredictably can cause injury.



Tools left connected to the air supply can start unexpectedly.

Always remove tool from air supply and activate trigger to bleed air line before making any adjustments, changing accessories, or doing any maintenance or service on tool. Make it a habit to check to see that all adjusting keys and wrenches have been removed from tool before turning it on.

Tools starting unexpectedly and flying keys and wrenches can cause injury.



Working in poorly lit areas makes it hard to see hazards.

Keep work area well lit.

Poorly lit work areas can cause injury.



Children are attracted to work areas.

Keep children away. All visitors must keep a safe distance away from work area.

Children in work areas can be injured.



Unauthorized or untrained personnel can misuse unattended tools.

Store idle tools in a dry, high or locked-up place, out of the reach of children.

Misused tools can cause injury.



Tools with the actuator left in the "ON" position when an unexpected air pressure loss occurs can start unexpectedly when the air pressure is restored.

Release the actuator if an unexpected loss of air pressure occurs.

Unexpected tool starts can cause injury.



Grinders with the actuator left in the "on" position can cause unexpected starts when the tool is connected to the air supply.

Be sure actuator is off before hooking up air.

Unexpected starts can cause injury.



Grinders may coast for a short time after the trigger is released.

Be sure tool has come to a complete stop before setting it aside.

Grinders that do not come to a complete stop before setting aside can cause injury.



Cut off wheels or router bits are not rated for the high speed of die grinders and could explode or fly apart.

Do not use cut off wheels or router bits with die grinders.

Exploding or flying parts can cause injury.



The use of any accessory with this tool not provided or specified by Sioux Tools can perform unpredictably.

Use only accessories provided or specified by Sioux Tools.

Tools that perform unpredictably can cause injury.

When disposing of a tool, do it in a way that does not harm personnel or the environment.

INTENDED USE

This tool is intended for use with small mounted abrasive wheel for precision material removal. Mounted wheels are defined as abrasive wheels that are secured to plain or threaded mandrels.

AIR SUPPLY

The efficiency and life of this tool depend on the proper supply of clean, dry air at a maximum of 90 PSI. The use of an air line filter, pressure regulator, and lubricator is recommended.

Before connecting to tools, blow out the air line to remove water and dirt that may have accumulated.

HOSE AND HOSE CONNECTIONS

The air supply hose recommended is 3/8" (10mm) I.D. If an extension hose is necessary, use 1/2" (13mm) ID hose with couplings not less than 3/8" (10mm) I.D.

LUBRICATION

All models may operate without airline lubrication. However, operating the tool without airline lubrication may reduce tool performance and vane life. If an airline lubrication is not used, it is recommended that the tool be oiled daily before use to improve performance. Add 2-4 drops of air motor oil and run the tool for 10-20 seconds to distribute oil through the tool.

For maximum performance and tool life, an air line lubricator, set to deliver 2 drops per minute, is recommended. SIOUX No. 288 Air Motor Oil is recommended.

MAINTENANCE

Water, dust and other airline contaminants can cause rust and vane sticking. For long periods between tool use, flush the tool with a few drops of oil and run for 10 seconds. This will help remove contaminants and reduce the formation of rust.

OPERATION

The tool is equipped with a locking type lever in order to prevent accidental start-up.

Speed of the tool may be adjusted by turning the regulator, which is located opposite the throttle lever.

⚠ WARNING	
	Disconnect tool from air supply before installing or removing taps or making any adjustments

INSTALLING MOUNTED WHEELS

Insert the mounted wheel into the collet. Make sure the wheel shank and the collet size match. Do not allow the wheel to extend beyond the collet an excessive distance.

Hold the collet body with a 9/16" (14mm) wrench and the collet nut with a 3/4" (19 mm) wrench.

Turn the collet nut to the right and firmly tighten the collet on to the wheel shank.

REMOVING MOUNTED WHEELS

To remove the mounted wheel, hold the collet body with a 9/16" (14 mm) wrench and the collet nut with a 3/4" (19 mm) wrench.

Turn the collet nut to the left and loosen the collet.

Remove the mounted wheel.

NOISE AND VIBRATION READINGS					
Catalog Number	Noise* (Tested in accordance with ISO Standard 15744)			Vibration* (Tested in accordance with ISO Standard 28927-3:2009)	
	*Sound Pressure (dBA)	*Sound Power (dBA)	Uncertainty (dBA)	*Vibration m/s ²	Uncertainty m/s ²
SDG7S	79.9	91.5	3.0	2.83	3.0



**PARTS LIST FOR CASTLE TOOL
SDG SERIES STRAIGHT DIE GRINDERS
SERIAL "A"**

HOUSING ASSEMBLY

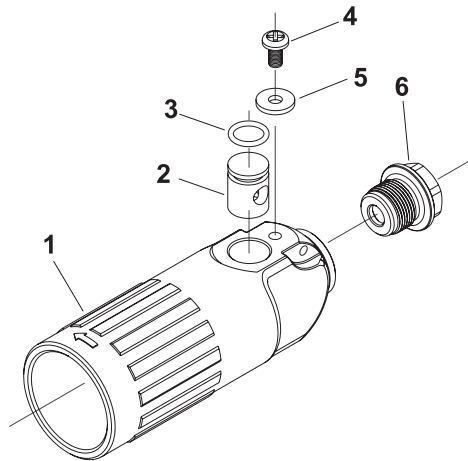
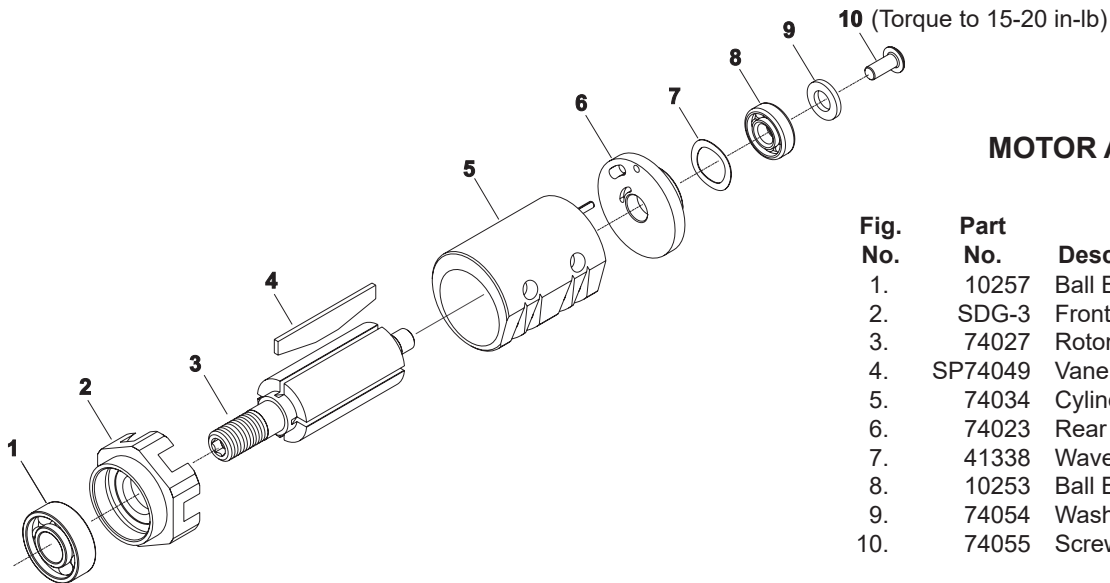
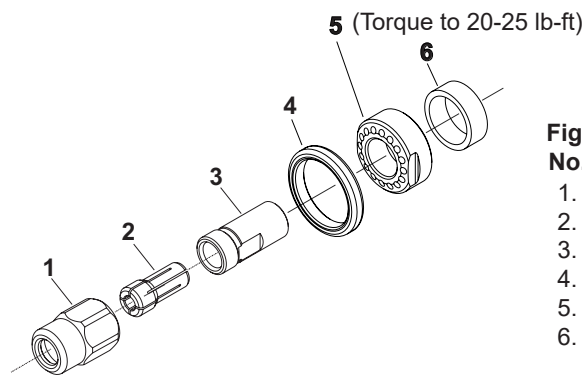

Fig. No.	Part No.	Description
1.	SDG-70	Housing
2.	64064CT	Valve Plug
3.	14290	O-Ring
4.	06650	Screw (#8-18 X 5/8 Pan Phillips Machine)
5.	25196	Washer
6.	SP66244	Inlet Adapter



MOTOR ASSEMBLY

Fig. No.	Part No.	Description
1.	10257	Ball Bearing 3/8 X 7/8 X 9/32
2.	SDG-3	Front End Plate
3.	74027	Rotor, 5 Slot
4.	SP74049	Vane, Set of 5
5.	74034	Cylinder (25,000 RPM)
6.	74023	Rear End Plate
7.	41338	Wave Washer .440 X .618 X .008
8.	10253	Ball Bearing
9.	74054	Washer .251 X .468 X .063
10.	74055	Screw #8-32 X 3/8 But Hd Cap



COLLET ASSEMBLY

Fig. No.	Part No.	Description
1.	21097	Collet Nut
2.	44440	Collet (1/4")
3.	21096	Collet Body
4.	44537	Thread Cover
5.	64065	Retainer
6.	04046	Silencer Pad

*Order Quantity As Required

**FURNISH CATALOG, SERIAL, AND MODEL NUMBER WHEN
ORDERING PARTS**



⚠ WARNING



Some dust created by power sanding, sawing, grinding, drilling, and other construction activities contains chemicals known to cause cancer, birth defects or other reproductive harm.

⚠ ADVERTENCIA



El polvo generado al lijar, aserrar, afilar, taladrar y realizar otras tareas de construcción contiene compuestos químicos que podrían provocar cáncer, malformaciones congénitas y otras alteraciones del aparato reproductor.



This pdf incorporates the following model numbers:

SDG7S25FCT