



# Model 5040

## 3/8" Sq. Drive Butterfly Lever Impact Wrench

Form # Z397  
Date 11-97/A



**IMPORTANT**

**Read these instructions carefully before installing, operating, servicing or repairing this tool. Keep these instructions in a safe accessible place.**

<p><b>SAFETY MESSAGES</b></p> <p align="center">Personal Safety Equipment</p> <p>Use – Safety Glasses <b>YES</b></p> <p>Use – Safety Gloves</p> <p>Use – Safety Boots</p> <p>Use – Breathing Masks</p> <p>Use – Ear Protectors <b>YES</b></p>	<p><b>WARNING</b></p> <p> Always Read Instructions Before Using Power Tools</p> <p> Always Wear Safety Goggles</p> <p> Wear Hearing Protection</p> <p> Avoid Prolonged Exposure To Vibration</p>	<p><b>Operator Instructions</b></p> <p><b>Includes:</b></p> <p><b>Safety Rules</b></p> <p><b>Foreseen Use</b></p> <p><b>Work Stations</b></p> <p><b>Putting Into Service</b></p> <p><b>Operating</b></p> <p><b>Dismantling and Assembly.</b></p>
---	--	--

### Safety rules when using a 5040 Impact Wrench

- Use only impact sockets and extensions, universal joints, etc., rated as being suitable for use with impact wrenches.
- Prolonged exposure to vibration may cause injury.
- Read all instructions before using this tool. All operators must be fully trained in its use and aware of these safety rules.
- Do not exceed the maximum working air pressure.
- Use personal protection equipment as recommended.
- Use compressed air only at the recommended conditions.
- If the tool appears to malfunction, remove from use immediately and arrange for service and repair. If it is not practical to remove tool from service, then shut off the air supply to the tool and write or have written a warning note and attach it to the tool.
- If tool is to be used with a balancer or other suspension device, ensure that the tool is firmly attached to the suspension/support device.
- When operating the tool, always keep the body and particularly the hands away from the working attachment fixed to the tool.
- The tool is not electrically insulated. Never use the tool if there is any chance of coming into contact with live electricity.
- Always when using the tool, adopt a firm footing and/or position and grip the tool sufficiently only to overcome any reaction forces that may result from the tool doing work. Do not overgrip.
- Use only correct spare parts for maintenance and repair. Do not improvise or make temporary repairs. Major servicing and repairs should only be carried out by persons trained to do so.
- Do not lock, tape, wire, etc. the 'On/Off' valve in 'On' position. The throttle trigger/lever, etc. must always be free to return to the 'Off' position when released.
- Always shut off the air supply to the tool and press the 'On/Off' valve to exhaust the air from the feed hose before fitting, removing or adjusting the working attachment fitted to the tool.
- Before using the tool, make sure that a shut off device has been fitted to the supply line and the position is known and easily accessible so that the air supply to the tool can be shut off in an emergency.
- Check hose and fittings regularly for wear.
- Take care against entanglement of the moving parts of the tool with clothing, hair, ties, cleaning rags, rings, jewelry, watches, bracelets, etc. This could cause the body or parts of the body to be drawn towards and in contact with the moving parts of the tool and could be very dangerous.
- It is expected that users will adopt safe working practices and observe all local, regional or country legal

- requirements when installing, using or maintaining the tool.
- Take care that the exhaust air does not point towards any other person or material or substance that could be contaminated by oil droplets. When first lubricating a tool or if the tool exhaust has a high oil content, do not allow the exhaust air to come near very hot surfaces or flames.
- Never lay the tool down until the working attachment has stopped moving.
- When the tool is not in use, shut off the air supply and press throttle trigger/lever to drain the supply line. If the tool is not to be used for a period of time, first lubricate, disconnect from air supply and store in a dry average room temperature environment.
- If the tool is passed from one user to a new or inexperienced user, make sure these instructions are available to be passed with the tool.
- Do not remove any manufacturer fitted safety devices where fitted, i.e., wheel guards, safety trigger, speed governors, etc.
- Wherever possible, secure workpiece with clamps, a vise, etc. to make it rigid so it does not move during the work operation. Keep good balance at all times. Do not stretch or overreach.
- Try to match the tool to the work operation. Do not use a tool that is too light or heavy for the work operation. If in doubt, seek advice.
- In general terms, this tool is not suitable for underwater use or use in explosive environments — seek advice from manufacturer.
- Try to make sure that the work area is clear to enable the work task to be performed safely. If practical and possible, try to clear unnecessary obstructions before starting work.
- Always use air hose and couplings with minimum working pressure ratings at least 1 1/2 times the maximum working pressure rating of the tool.

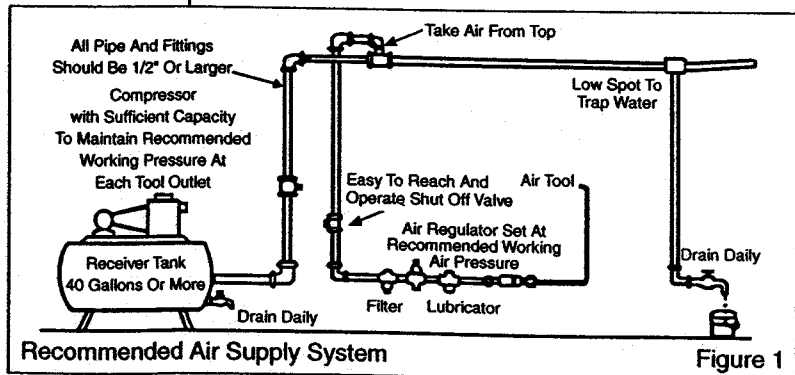

## Foreseen Use Of The Tool – 5040

The impact wrench is designed for the tightening and loosening of threaded fastener within the range as specified by the manufacturer. It should only be used in conjunction with suitable impact type 3/8" square female drive nut running sockets. Only use sockets which are of the impact type.

It is allowed to use suitable extension bars, universal joints and socket adaptors between the square output drive of the ratchet wrench and the female square drive of the socket.

Do not use the tool for any other purpose than that specified without consulting the manufacturer or the manufacturer's authorized supplier. To do so may be dangerous.

Never use an impact wrench as a hammer to dislodge or straighten cross threaded fasteners. Never attempt to modify the tool for other uses and never modify the tool for even its recommended use as a nutrunner.

## Work Stations

The tool should only be used as a handheld, hand operated tool. It is always recommended that the tool is used when standing on a solid floor. It can be used in other positions, but before any such use, the operator must be in a secure position having a firm grip and footing and be aware that when loosening fasteners the tool can move quite quickly away from the fastener being undone. An allowance must always be made for this rearward movement so as to avoid the possibility of hand/arm/body entrapment.

## Putting Into Service

### Air Supply

Use a clean lubricated air supply that will give a measured air pressure at the tool of 90 PSIG (6.2 bar) when the tool is running with the trigger/lever fully depressed. Use recommended hose size and length. It is recommended that the tool is connected to the air supply as shown in figure 1. Do not connect the tool to the air line system without incorporating an easy to reach and operate air shut off valve. The air supply should be lubricated. It is strongly recommended that an air filter, regulator, lubricator (FRL) is used as shown in Figure 1 as this will supply clean, lubricated air at the correct pressure to the tool. Details of such equipment can be obtained from your supplier. If such equipment is not used, then the tool should be lubricated by shutting off the air supply to the tool, depressurizing the line by pressing the trigger on the tool. Disconnect the air line and pour into the hose adaptor a teaspoonful (5ml) of a suitable pneumatic motor lubricating oil preferably incorporating a rust inhibitor. Reconnect tool to air supply and run tool slowly for a few seconds to allow air to circulate the oil. If tool is used frequently, lubricate on daily basis and if tool starts to slow or lose power.

It is recommended that joint tightness of the threaded fastener assembly be checked with a torque wrench.

It is recommended that the air pressure at the tool while the tool is running is 90 PSI/6.2 bar.

## Operating

The output of the impact wrench in prime working condition is governed by mainly three factors:

- a) the input air pressure;
- b) the time the impact wrench is operated on the joint. Normal time for joints of average tension requirement 3 to 5 seconds;
- c) the setting of the air regulator for a given joint at a given pressure operated for a given time.

The air regulator (47) can be used to regulate the output of the impact wrench if no other means of control is available. It is strongly recommended that an external pressure regulator, ideally as part of a filter/regulator/lubricator (FRL), is used to control air inlet pressure so that the pressure can be set to help control the tension required to be applied to the threaded fastener joint.

There is no consistent, reliable torque adjustment on an impact wrench of this type. However, the air regulator can be used to adjust torque to the approximate tightness of a known threaded joint. To set the tool to the desired torque, select a nut or screw of known tightness of the same size, thread pitch and thread condition as those on the job. Turn air regulator to low position, apply wrench to nut and gradually increase power (turn regulator to admit more air) until nut moves slightly in the direction it was originally set. The tool is now set to duplicate that tightness, note regulator setting for future use. When tightening nuts not requiring critical torque values, run nut up flush and then tighten an additional one-quarter to one-half turn (slight additional turning is necessary if gaskets are being clamped). For additional power needed on disassembly work, turn regulator to its fully open position. This impact wrench is rated a 3/8" bolt size.

Rating must be downgraded for spring U bolts, tie bolts, long cap screws, double depth nuts, badly rusted conditions and spring fasteners as they absorb much of the impact power. When possible, clamp or wedge the bolt to prevent springback.

Soak rusted nuts in penetrating oil and break rust seal before removing with impact wrench. If nut does not start to move in three to five seconds use a larger size impact wrench. Do not use impact wrench beyond rated capacity as this will drastically reduce tool life.

NOTE: Actual torque on a fastener is directly related to joint hardness, tool speed, condition of socket and the time the tool is allowed to impact.

Use the simplest possible tool-to-socket hook up. Every connection absorbs energy and reduces power.

The direction of rotation of this tool is controlled by the throttle lever. Be sure that it is known which side of the lever has to be pressed to give the required direction of rotation before applying the impact wrench to the joint to be fastened or loosened.

For best results:

- 1) Always use the correct size impact type socket.
- 2) Use extra deep sockets in place of extension bars where possible.
- 3) Do not use oversized, worn or cracked sockets.
- 4) Hold the wrench so the socket fits squarely on the fastener. Hold the wrench firmly, but not too tightly, pressing slightly forward.

## Dismantling & Assembly Instructions

Disconnect tool from air supply.

Pry off rubber nose guard (1) from motor housing (5). Remove oiler screw (3) and O-ring (4) and drain oil from the front end into a suitable container. Grip the tool in a vise locating on the square drive of the anvil (12). Unscrew 2 screws (50) and remove 2 lock washers (49) and retainer plate (48). Pull out air regulator (47) complete with O-ring (46) being careful not to lose ball (44) and spring (45). Tap pin (36) with a suitable punch as far as possible out of the assembly, but still allow the assembly to rotate. It is now necessary to grip the length of the pin driven through the assembly and pull it out taking care not to deform it. Lift off collar (37) and pull out inlet bushing (43). O-rings (41) and (42) may be removed from the stem on inlet bushing (43). Unscrew 2 cap screws (39) and 2 cap screws (40) and remove together with 4 lock washers (38) to release back cap (30) and gasket (29) from the assembly. At this stage, remove throttle lever (7) together with 2 throttle pins (6). From back cap assembly pull off 2 plungers (31) and remove 2 springs (32) and 2 valves (33). It is then possible to lever out 2 valve seats (34) and 2 springs (35) taking care to protect the eyes as the springs can fly out when released. Pull out motor pin (22) and extract the assembly comprising of retaining ring (28), rear end plate (26), bearing (27), rotor (24), 6 rotor blades (23) and cylinder (25). Note at this time the way the cylinder (25) is removed and note that it must be reassembled in the same way with the chamfer on the outside diameter to end face at the front end of the tool. Remove rotor blades (23) from rotor (24), take off retaining ring (28) and pull rotor (24) through rear end plate (26) and bearing (27) assembly. Using a suitable punch, bearing (27) may be removed from rear end plate (26). Pull out front end plate (21) complete with O-ring (20) and carefully pry off the O-ring. Remove bearing (17) and oil seal (18) from front end plate (21). Remove retaining ring (19) from motor housing (5) and take out the complete hammer mechanism. Take off O-ring (15) from cage (16) to remove hammer (14), 2 cage pins (13) and anvil (12). O-ring (10) may be levered off and O-ring (11) removed from anvil (12). Oil seal (2) may be hooked out of and anvil bushing (8) pressed out of motor housing (5).



# 5040 3/8" Square Drive Butterfly Lever Impact Wrench

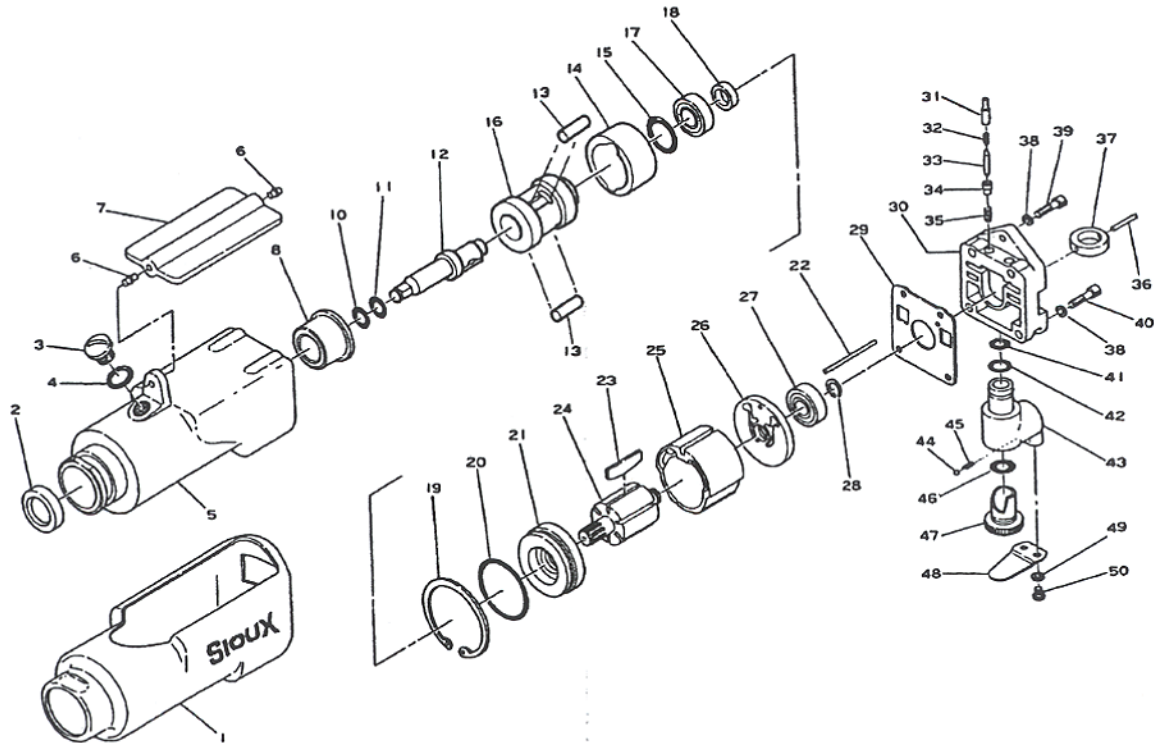

Ref. No.	Part No.	Description
1	67163	Housing Cover
2	67164	Oil Seal
3	67165	Plug
4	67037	O-Ring
5	67166	Motor Housing
6	67167	Throttle Lever Pin (2)*
7	67168	Throttle Lever
8	67169	Anvil Bushing
10	67171	Socket Retainer Ring
11	67172	Rubber Ring
12	67173	3/8" Sq. Anvil (includes Fig. 10 & 11)
13	67174	Hammer Pin (2)*
14	67388	Hammer
15	67175	Cage O-Ring
16	67176	Hammer Cage
17	67177	Ball Bearing
18	67178	Oil Seal
19	67179	Retaining Ring
20	67180	O-Ring
21	67181	Front Plate
22	67182	Motor Pin
23	67183	Rotor Blade (Set of 6)
24	67184	Rotor
25	67185	Cylinder
26	67186	Rear Plate

Ref. No.	Part No.	Description
27	66504	Ball Bearing
28	67187	Retaining Ring
29	67188	Motor Gasket
30	67189	Housing Cap
31	67190	Plunger (2)*
32	67191	Plunger Spring (2)*
33	67192	Valve Pin (2)*
34	67193	Valve (2)*
35	67194	Valve Spring (2)*
36	67195	Roll Pin
37	67196	Collar
38	67197	Washer (4)*
39	67198	Cap Screw (2)*
40	67010	Cap Screw (2)*
41	67199	O-Ring
42	67200	O-Ring
43	67201	Inlet Bushing
44	67202	Steel Ball
45	67203	Spring
46	66600	O-Ring
47	67204	Air Regulator
48	67205	Retainer Plate
49	67206	Lock Washer (2)*
50	67207	Screw (2)*
Not Shown	67384	Name Plate (5040)



\*Order Quantity as Needed

## Reassembly

Clean all parts and examine for wear. Examine O-rings and seals for signs of cuts and wear, etc. Particularly examine anvil (12) around the area of the square drive, hammer (14), cage (16) and cage pins (13) for cracks and wear. Replace parts with parts obtained from the manufacturer or an authorized distributor. Lightly coat all parts with a suitable pneumatic tool lubricating oil and reassemble in the reverse order. On completing the assembly, make sure the anvil is free to rotate and the lever and regulator operate freely. Remove oiler screw (3) and O-ring (4) and pour into the front end 3/8 fluid oz. (12cc) of a SAE20W oil. Replace oiler screw (3) and O-ring (4). Pour approx. 5ml of a pneumatic tool lubricating oil into the air inlet, connect to a suitable air supply and operate tool slowly for a few seconds to allow the oil to circulate and reset for operation - see section "Operating".

Operation Specification	
Air Consumption	9 cfm (64 scfm)
Maximum Torque	50 lbs ft (68Nm)
Working Torque	10-50 lbs ft (13-68Nm)
Air Inlet Thread	1/4-18NPT
Overall Length	5.7" (145mm)
at 90 PSIG	

NOTES
-------

<b>Manufacturer/Supplier</b> <b>Sioux Tools Inc.</b> <b>2901 Floyd Boulevard</b> <b>P.O. Box 507</b> <b>Sioux City, IA 51102</b> <b>U.S.A.</b> <b>Tel No. 712-252-0525 Fax No. 712-252-4267</b>		<b>Product Type</b> <b>3/8" Sq. Drive Butterfly</b> <b>Lever Impact Wrench</b>	<b>RPM</b> <b>10,000</b> <small>Cycles Per Min.</small>	
		<b>Model No/Nos</b> <b>5040</b>	<b>Serial No.</b>	
<b>Product Net Weight</b> <b>2.2 lbs</b> <b>1.0 Kg</b>	<b>Recommended Use Of</b> <b>Balancer Or Support</b> <b>NO</b>	<b>Recommended Hose Bore</b> <b>Size - Minimum</b> <b>5/16 Ins 8 MM</b>	<b>Recommended Max.</b> <b>Hose Length</b> <b>30 Ft 10 M</b>	
<b>Air Pressure</b> <b>Recommended Working</b> 6.2 bar 90 PSI <b>Maximum</b> 6.2 bar 90 PSI		<b>Noise Level: Sound Pressure Level 87.0 dB(A)</b> <b>Sound Power Level 98.0 dB(A)</b> <b>Test Method: Tested in accordance with Pneurop</b> <b>test code PN8NTC1 and ISO Standard 3744</b>		
<b>SAFETY MESSAGES</b> <b>Personal Safety Equipment</b> <b>Use - Safety Glasses YES</b> <b>Use - Safety Gloves</b> <b>Use - Safety Boots</b> <b>Use - Breathing Masks</b> <b>Use - Ear Protectors YES</b>	 <b>WARNING</b> Always Read Instructions Before Using Power Tools Always Wear Safety Goggles Wear Hearing Protection Avoid Prolonged Exposure To Vibration	<b>Vibration Level</b> <b>Less than 2.5 Meters / Sec<sup>2</sup></b> <b>Test Method: Tested in accordance with ISO</b> <b>standards 8662 Parts 1 &amp; 7</b>		

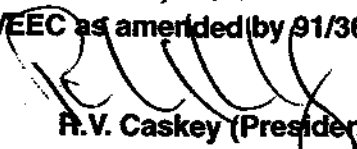
	<b>Declaration of Conformity</b> <b>Sioux Tools Inc.</b> <b>2901 Floyd Boulevard, P.O. Box 507, Sioux City, Iowa 51102</b> declare under our sole responsibility that the product <b>Model 5040 Butterfly Lever Impact Wrench, Serial Number</b> to which this declaration relates is in conformity with the following standard(s) or other normative document(s) <b>EN792 (Draft), EN292 Parts 1 &amp; 2, ISO 8662 Parts 1 &amp; 7, Pneurop PN8NTC1</b> following the provisions of <b>89/392/EEC as amended by 91/368/EEC &amp; 93/44/EEC Directives</b>
 <b>R.V. Caskey (President)</b>	
<small>Name and signature or equivalent marking of authorized person</small>	

This pdf incorporates the following model numbers:  
5040