



**NOTE: Parts are no longer available for this tool.**

**The manual will continue on the next page.**



# INSTRUCTIONS & PARTS LIST FOR 1630ES VACUUM TESTER

Form Z557  
Date 5-03/B  
Page 1 of 2

\*Order Quantity As Required  
FURNISH CATALOG, SERIAL, AND MODEL  
NUMBER WHEN ORDERING PARTS

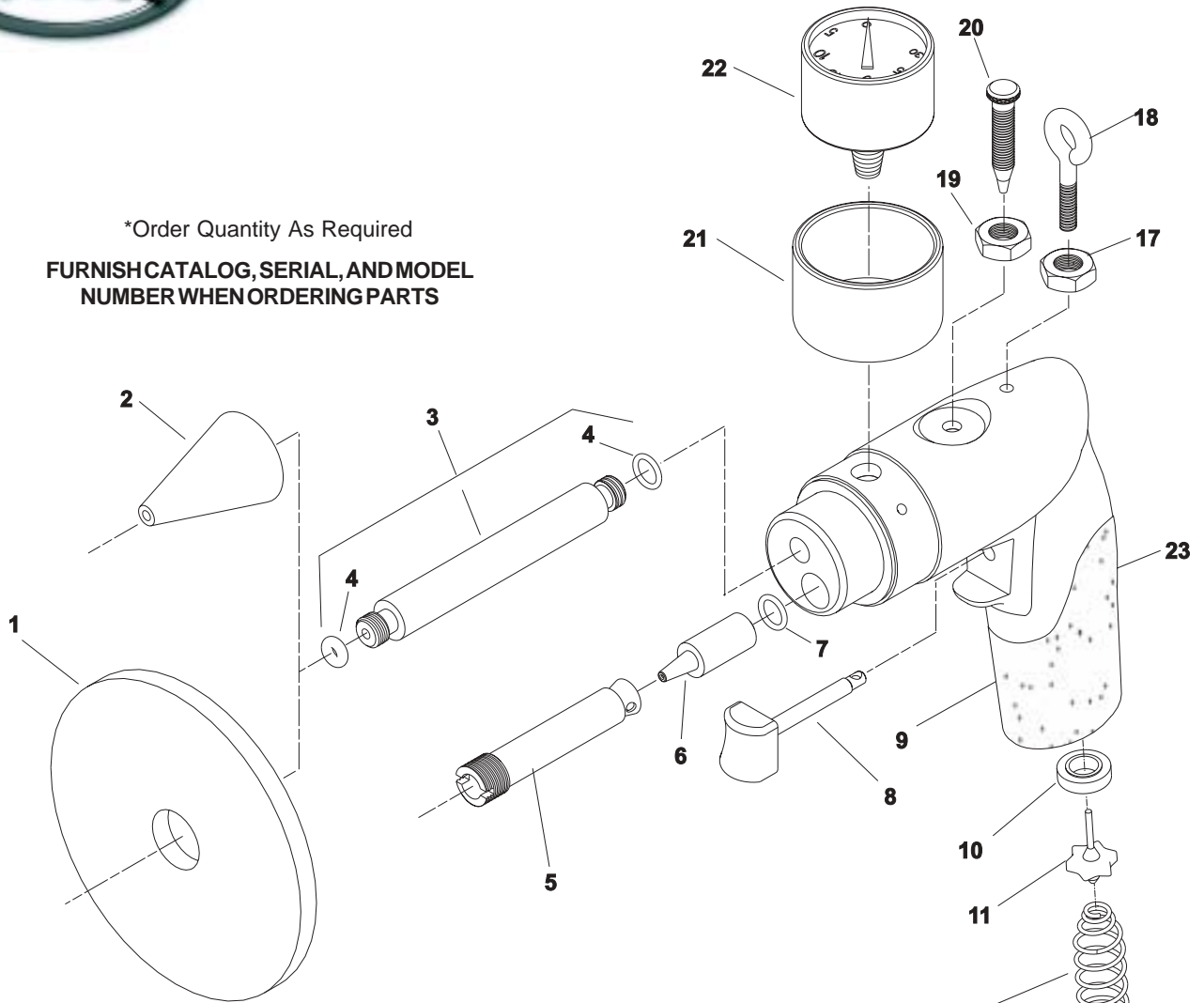

Fig. No.	Part No.	Description
1.	1630-2	2" Disc & Pad
	04318-2	2" Pad
	1630-3	3" Disc & Pad
	04318-3	3" Pad
	1630-4	4" Disc & Pad
	04318-4	4" Pad
	1630-6	6" Disc & Pad
	04318-6	6" Pad
2.	1630C	Plug Adapter
3.	64052	Tube 4"
	1630B	Flex Hose
4.	14291	Ring-"O" (4)*
5.	64048	Ejector
6.	64047	Orifice
7.	14311	Ring-"O"

Fig. No.	Part No.	Description
8.	67805	Ass'y-Trigger
9.	68035	Housing
10.	67798	Seat-Valve
11.	67804	Valve
12.	67828	Spring
13.	14281	Ring-"O"
14.	54955	Adapter-Inlet
15.	30463	Screen
16.	21541	Ring-Retaining
17.	09464	Nut
18.	07150	Eyebolt
19.	09510	Nut-Nylon
20.	64051	Screw-Air
21.	04320	Gage Protector
22.	64054	Gage-Vacuum
23.	67806	Cover-Handle

**SIoux  
TOOLS INC.**

250 SNAP-ON DRIVE ■ PO BOX 1596 ■ MURPHY, NC 28906 ■ USA ■

Printed In U.S.A.



## INSTRUCTIONS & PARTS LIST FOR 1630ES VACUUM TESTER

The Sioux No. 1630ES vacuum tester operates on the ejector principal, where a vacuum is generated by compressed air flowing through a pair of orifices. This tester is suitable for use in all instances where a vacuum supply of 18" Hg. or less is required. The tool will operate satisfactorily with an air supply of 70-140 PSI. although 90 PSI is optimum.

Leaks are detected by a drop in vacuum as shown by the gauge. Larger leaks will show up as larger drops in vacuum.

An adjustment screw is provided on top of the tool to vary the sensitivity of the gauge. This screw limits the vacuum airflow into the tool, making any leak a higher percentage of the total flow. This results in a larger drop in vacuum at the gauge for a given leak.

To check valve seats for leaks the adjustment screw should be set for maximum sensitivity. To set the adjustment screw for maximum sensitivity, do the following steps.

1. Plug the vacuum inlet; pull the air supply trigger.
2. Back out the adjustment screw until a maximum vacuum is seen. (Approx. 18" of Hg.)
3. Turn the screw in until a vacuum drop of 1" occurs.
4. Tighten down the nylon nut to prevent any air leaks from giving false leakage reading.

The tool is now at its maximum sensitivity setting.

You are now ready to test valve sealing. Mount the appropriate size disc to cover the valve port that you wish to test. Press the disc firmly over the valve port and pull the trigger.

The vacuum reading should be at least one-half the maximum vacuum reading with the inlet pipe plugged. If the reading is less than one-half, add a small amount of oil to the valve stem and repeat the test. If the reading now shows a full vacuum you may have a worn stem or guide. If the vacuum did not rise significantly, then you have a leak between the valve face and seat. On multi-valve heads you should add a small amount of oil to each valve seat area in turn to determine which one leaks. This test may also be done from combustion chamber side if the valve springs are in place and the plug or injector holes are plugged. This method is sometimes necessary if there is an EGR, heat riser, or vacuum port that cannot be stopped off.

To test piston rings, back the adjusting screw out a few turns and lock down the nylon nut to prevent air leaks. Attach the proper disc to the tool and place over the cylinder. Since all rings have a small end gap some leakage will occur, even in good engines. What we are looking for here is a large leak, indicating a broken ring or worn parts. This test can also be performed on a complete engine by using the tapered adapter in a spark plug, glow plug, or injector opening. If this test is done, care should be used to insure that both valves are fully closed. Tests done in this manner will insure the condition of the entire combustion system.

The vacuum tester can also be used to test vacuum and pollution control devices. Vacuum level can be varied by adjusting the air pressure going into the tool. When used in conjunction with a collection jar the vacuum tester can be used as a power brake bleeder. The tool can also be used to test crankcase seals on 2-stroke engines if the inlet and exhaust ports are stopped off.

### MAINTENANCE

The only maintenance necessary is to clean the inlet screen, orifice, or ejector if they become clogged. This is necessary when the tool will no longer produce a normal reading. Do not blow compressed air into the vacuum inlet, as this will damage the vacuum gauge. When reassembling, be sure to use thread sealing compound or tape on the gauge and ejector threads to prevent vacuum leaks.

**SIoux  
TOOLS INC.**

250 SNAP-ON DRIVE ■ PO BOX 1596 ■ MURPHY, NC 28906 ■ USA ■

Printed In U.S.A.

This pdf incorporates the following model numbers:

1630ES