



NOTE: Parts are no longer available for this tool.

The manual will continue on the next page.



Parts List for NO. 564 PNEUMATIC CUT OFF TOOL (SERIAL "B")

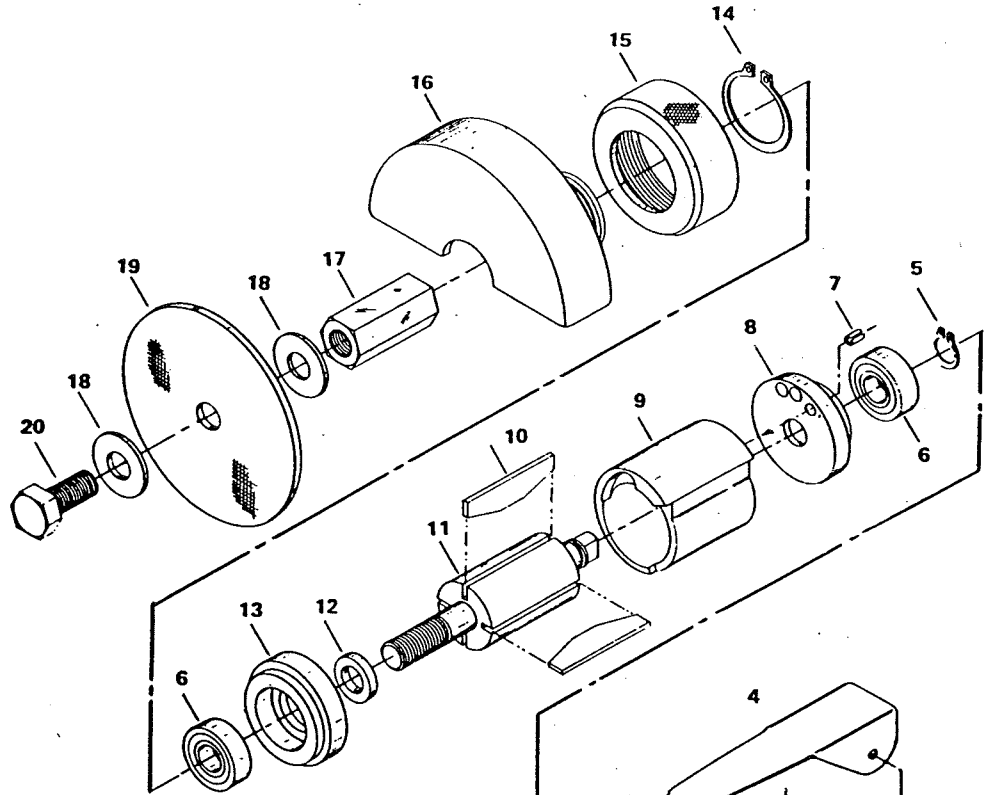
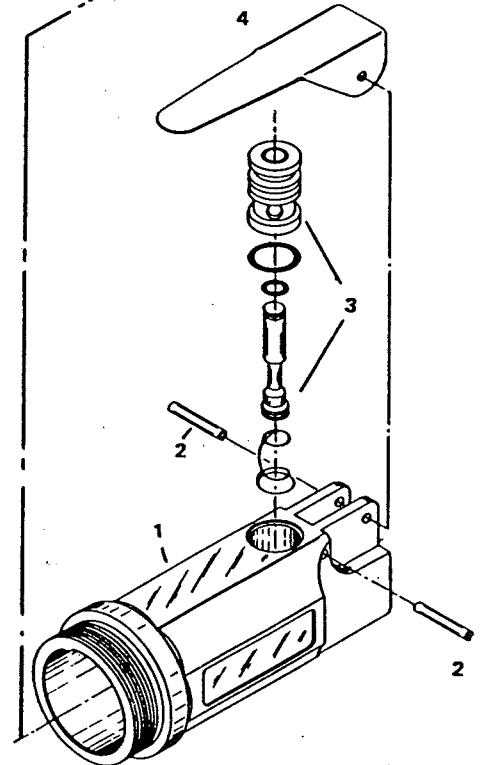

Fig- ure	Part No.	Name
1	72402	Housing
2	30694	Roll Pin (Pkg. of 2)
3	72386	Trigger Assembly
4	72374	Trigger Lever
5	21534	Retaining Ring (New)
6	72403	Ball Bearing (Pkg. of 2)
7	72407	Roll Pin (New)
8	72404	Rear End Plate
9	72406	Cylinder
10	72390	Rotor Vanes (Pkg. of 4)
11	72405	Rotor
12	72408	Spacer
13	72409	Front End Plate
14	21484	Retaining Ring
15	72396	Lock Nut
16	72397	Guard Housing
17	72395	Hex Adapter
18	72398	Washer (2 req.)
19	2003	Five Replacement Wheels
20	72399	Bolt



**SIoux
TOOLS INC.**



INSTRUCTIONS FOR NO. 564 PNEUMATIC CUT OFF TOOL

SAFETY INSTRUCTIONS

1. READ ALL INSTRUCTIONS CAREFULLY before operating your cutter.
2. Do **NOT** operate this tool without the safety wheel guard in place.
3. BEFORE MOUNTING WHEELS, and before placing the tool in service, check the free running spindle speed with 100 PSI at tool inlet. The tool's speed should be checked after every 50 hours of usage.
4. ALWAYS WEAR EYE PROTECTION. Use a dust mask if the operation creates dust. Caution is the key to safety.
5. PROTECT YOURSELF FROM NOISE. Noise levels vary with work surface. If noise level from cutting is high, wear ear protectors.
6. WEAR GLOVES AND PROTECTIVE CLOTHING to avoid injuries caused by chips or pieces, malfunctioning attachments, or improperly clamped work.
7. NEVER USE THE CUTTER AT AIR PRESSURE ABOVE 100 PSI AT TOOL INLET. THIS IS AN UNGOVERNED TOOL AND ITS FREE SPEED WILL INCREASE IN PROPORTION TO ANY INCREASE IN AIR PRESSURE ABOVE 100PSI. Control air pressure with a reliable automatic air regulator. Periodically, monitor air pressure at tool's air inlet while tool is running free speed.
8. USE ONLY CUTTING WHEELS with an R.P.M. (speed) rating AT or ABOVE the ACTUAL free speed of the cutter. THE RATED FREE RUNNING SPEED OF THIS TOOL is 20,000 RPM.
9. DISCONNECT TOOL FROM AIR SUPPLY BEFORE CHANGING OR INSPECTING WHEELS OR GUARD. Do not perform service work on tool while connected to an air supply.
10. IF A SUDDEN CHANGE OCCURS in the feel (vibration level) or sound (pitch) of the unit, the tool should be IMMEDIATELY TURNED OFF and the work head inspected for damage. Do not use cracked or chipped wheels.
11. HANDLE THE TOOL SAFELY. Do not carry the tool with a finger on or near the throttle or trigger while the tool is connected to an air supply. Do not carry the cutter by the hose. Protect the hose from heat and sharp objects.
12. WHEN NOT IN USE, DISCONNECT TOOL FROM AIR SUPPLY to prevent accidental or unauthorized use in the absence of the operator.
13. KEEP VISITORS AT A SAFE DISTANCE and out of line with the tool's work head and work surface.
14. Do not alter any part or parts of the components of this tool in any way, shape or form.

AIR SUPPLY AND CONNECTIONS:

The cutter is designed to operate at 100 PSI maximum air pressure at the tool when the tool is running. Less pressure prevents the tool from delivering its rated power. Air pressure over 100 PSI at the tool will cause tool to over speed and may result in tool exceeding the accessory strength. The air supply must be water-free; therefore, a drop line or water trap should be used to remove condensation. In addition an air line lubricator is strongly recommended to insure proper operation and long life of motor and valve parts.

The minimum pipe size to be used is 1/4" and no fitting should be used that has an orifice of less than 7/32" diameter. If a quick disconnect coupler is used, it should not be attached directly at the handle of the wrench, but spaced off with a hose whip; otherwise, breakage of fittings may result.

OPERATION:

1. READ SAFETY INSTRUCTIONS:
2. The tool is started by depressing the throttle, which is spring loaded and returns to the OFF position when released.
3. Always wear safety goggles and protective clothing when operating the tool.

GENERAL MAINTENANCE:

A parts breakdown on the back page of this owner's manual shows all the parts incorporated in the tool. Refer to this sheet when cleaning, inspecting, or when ordering parts becomes necessary.

ROTOR BLADES—Blade life depends upon proper lubrication. Inspect all blades several times a year and replace when they are less than .23 wide. It is suggested that a spare set of blades be kept on hand at all times, and that all moving parts of the tool be inspected when blades are replaced.

LUBRICATION—When tool is new, be sure to lubricate motor before using. If in-line lubricator is not used, add a few drops of oil into air inlet daily. Heavy oils are not recommended.

OPERATIONAL SPECIFICATIONS:

Standard Operating Pressure.....	90-100 psig (620-690 kPa)
Air Consumption.....	4 CFM (28 SCFM)
Free Running Speed.....	20,000 RPM
Air Inlet Thread Size.....	1/4" (6.35 mm)-18 NPT
Recommended Hose Size.....	3/8" (9.5 mm) I.D.
Noise Level.....	103 dBA (at 90 psig)

This pdf incorporates the following model numbers:

564