

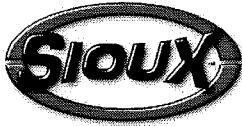

NOTE: Parts are no longer available for this tool.

The manual will continue on the next page.



PARTS LIST FOR NO. 1645M 1/4" LUBRICATORS

Form No. A308C
Date 3/93

WARNING

DO NOT PLACE PLASTIC BOWL UNIT IN SERVICE WITHOUT METAL BOWL GUARD INSTALLED

Plastic bowl units are sold with metal bowl guards. To minimize the danger of flying fragments in the event of plastic bowl failure, the metal bowl guards should not be removed. If the unit is in service without the metal bowl guard installed, manufacturer's warranties are void, and the manufacturer assumes no responsibility for any resulting loss.

IF UNIT HAS BEEN IN SERVICE AND DOES NOT HAVE A METAL BOWL GUARD, ORDER ONE AND INSTALL BEFORE PLACING BACK IN SERVICE.

For information on materials harmful to plastic bowls, contact a Mobay Chemical or General Electric office for information regarding materials that will attack polycarbonate plastic.

CAUTION

Certain compressor oils, chemicals, household cleaners, solvents, paints, and fumes will attack plastic bowls and can cause bowl failure. Do not use near these materials. When bowl becomes dirty replace bowl or wipe only with clean, dry cloth. Reinstall metal bowl guard or buy and install a metal bowl guard. Immediately replace any crazed, cracked, damaged, or deteriorated plastic bowl with a metal bowl or a new plastic bowl and metal bowl guard.

EXCEPT as otherwise specified by the manufacturer, this product is specifically designed for compressed air service and use with any other fluid (liquid or gas) is a misapplication. For example, use with or injection of certain hazardous liquids or gases in the system (such as alcohol or liquid petroleum gas) could be harmful to the unit or result in a combustible condition or hazardous external leakage. Manufacturer's warranties are void in the event of misapplication, and manufacturer assumes no responsibility for any resulting loss. Before using with fluids other than air, or for non-industrial applications, or for life support systems, consult manufacturer for written approval.

INSTALLATION

1. Refer to warning.
2. Install as close as possible to the equipment requiring lubrication.
3. Install unit with air flowing through the body in the direction indicated by arrow.
4. Install the same size unit as the pipe-size unit as the pipeline in use. Avoid using fittings, couplings, etc. that restrict the airflow or baffle the oil out of the air at the lubricator outlet.

OPERATION

1. Maximum pressure and temperature ratings are: for plastic bowls, 150 psig (10 bar) and 125°F (52°C); for metal bowls, 250 psig (17 bar) and 175°F (79°C).
2. The lubricator may be filled under pressure by removing the fill plug and pouring oil into the bowl through the fill port. NOTE: As the fill plug is removed the air pressure in the bowl will be released. The bowl may be taken off after the fill plug is removed if a more rapid fill is required. DO NOT replace the fill plug until the bowl and bowl guard are in position and the clamp ring is locked into place.
3. Use clean oil, preferably SAE 10 or lighter. The rate of oil delivery may be controlled by turning the adjusting screw counterclockwise for more and clockwise for less oil delivery. The lubricator delivers all the oil downstream that passes through the sight dome. The oil delivery rate will change automatically to deliver more oil during higher airflows, and less oil for airflows lower than that at which the original setting was made.

MAINTENANCE

1. Given clean operating conditions, this unit will be trouble-free. Drain off any contaminants which collect in the bottom of the bowl. Contaminants from dirty oil may collect on the siphon tube filter, requiring the filter to be washed in kerosene and blown off with an air blow gun.
2. IF THE OIL DELIVERY RATE DROPS, the lubricator should be cleaned. Shut off the air supply and reduce the pressure in the unit to zero. Remove the adjusting screw and clean the needle and seat in the body. Inspect and clean the passage from the needle seat down into the siphon tube adapter. Remove the Flow-Guide® variable orifice screw and clean its air passage with a small wire. Check the bore that the screw fits into for contaminant and clean if necessary. Be sure the passageway from the sight dome cavity downward is open. For plastic bowl units, the bowl may be cleaned by wiping with a clean dry cloth.

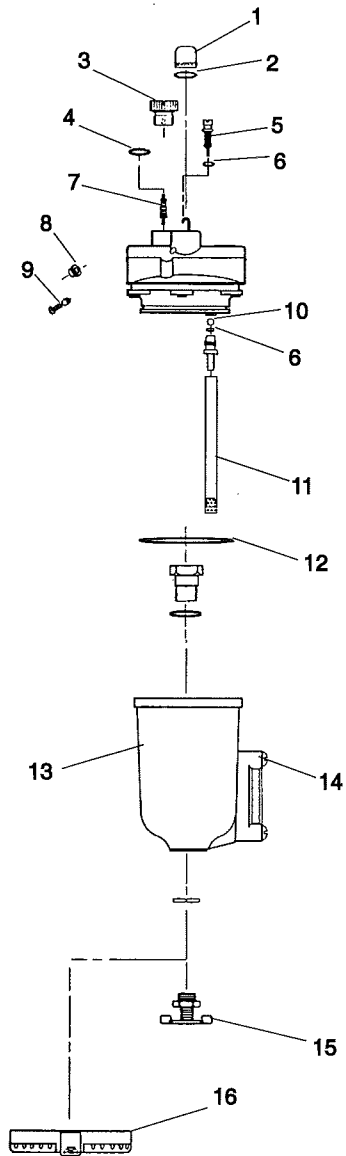

| Fig. No. | Part No. | Name |
|----------|----------|---|
| 1. | 00195 | Dome—Sight |
| 2. | 14378 | O-Ring |
| 3. | 00192 | Plug (Includes Fig. 4) |
| 4. | 14309 | O-Ring |
| 5. | 00193 | Screw—Adjustable |
| 6. | 14369 | O-Ring |
| 7. | 00190 | Valve—Check |
| 8. | 00188 | Flow Guide (1/4")(Includes Fig. 9) |
| 9. | 00187 | Screw—Flow Guide |
| 10. | 00033 | Ball |
| 11. | 00184 | Ass'y—Siphon Tube & Filter |
| 12. | 00183 | O-Ring |
| 13. | 00221 | Bowl—Metal (With Gauge) (Includes Fig. 15) |
| 14. | 00223 | Kit—Gauge Repair (Includes Glass Gauge Tube, O-Rings, & Gaskets to Service Oil Level Gauge) |
| 15. | 00039 | Drain—Cock |
| 16. | 00181 | Ring—Clamp |

**SIoux
TOOLS INC.**

250 SNAP-ON DRIVE ■ PO BOX 1596 ■ MURPHY, NC 28906 ■ USA ■

Furnish Catalog And Serial Number When Ordering Parts

Printed in U.S.A.

This pdf incorporates the following model numbers:

1645M