



**NOTE: Parts are no longer available for this tool.**

**The manual will continue on the next page.**



**SIoux  
TOOLS INC.**

2901 FLOYD BOULEVARD ■ SIOUX CITY, IOWA 51102 ■

# PARTS LIST

- 1274A Electric H.D. Sander 5000 R.P.M.
- 1275A Electric H.D. 7" Grinder 7000 R.P.M. Max.
- 1276A Electric H.D. Sander 6000 R.P.M.
- 1277A Electric H.D. 7" Grinder 6000 R.P.M. Max.
- 1279A Electric H.D. 9" Grinder 6000 R.P.M. Max.

(SERIAL "B")

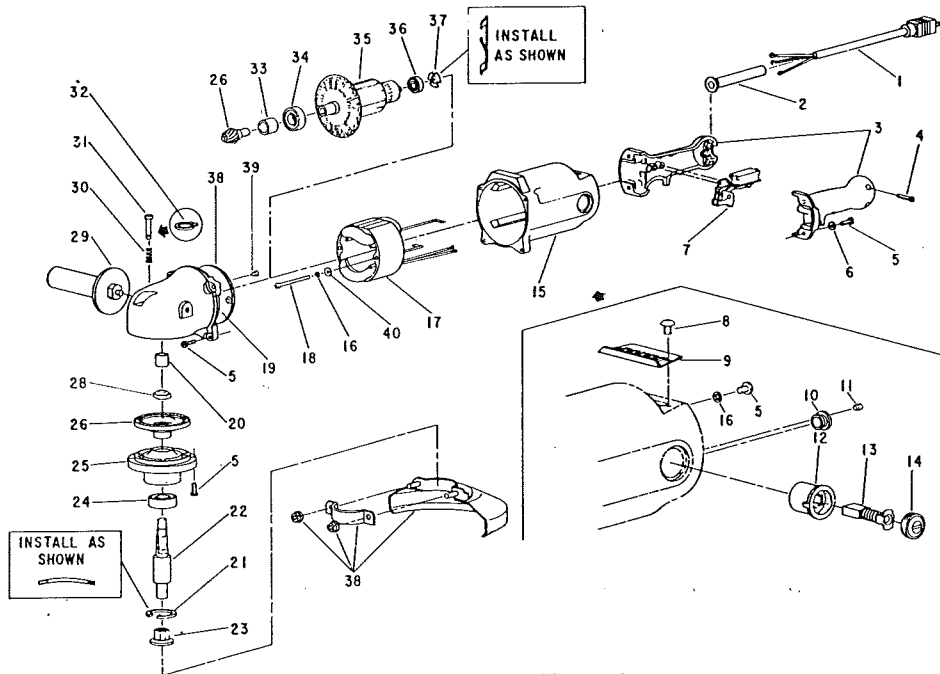

Fig. ure	Part No.	Name
1	18431	Cord W/Terminals
2	04295	Relief—Strain
3	63196	Ass'y.—Handle
4	06657	Screw—Phil. Pan Hd. (#8-32 x 1 1/8) (3)*
5	07248	Screw—Torx Pan Hd. (#10-32 x 3/4) (13)*
6	35234	Washer (4)*
7	18235	Switch
9	35830	Cover—Inspection Hole
10	04016	Bushing—Lead Insulating
11	07000	Screw—Soc. Hd. Cup Pt. Set (2)* (Torque to 9-10 in. Lbs.)
12	18088	Ass'y.—Brush Holder (2)*
13	18038	Brush (Set of 2)
14	18123	Cap—Brush Holder (2)*
15	12772	Housing [Includes Fig's. 10, 11 (2), 12 (2), 5 (9)]
16	09724	Washer—Lock (3)*
17	28893	Field
18	07134	Screw—Field (#10-24 x 2 1/2) (2)*
19	12677	Case-Gear [Incl's. Fig's. 20, 30, 31, 32 & 5 (4)]
20	10023	Bearing—Needle
21	21819	Ring—Retaining (Bowed)
22	64183	Spindle—Tool
23	524	Nut—Lock
24	10244	Bearing—Ball
25	12675	Support—Bearing & Bearing Ass'y. [Incl's. Fig's. 24 & 22]
26	19731	Ass'y.—Spiral Bevel Gear & Pinion

Fig. ure	Part No.	Name
28	09693	Nut—Lock (Torque to 55 Ft. Lbs. Min)
	21820	Ring—Retaining (Not Shown—used on older models)
	41331	Washer—Spring (Curved) (Not Shown—used on older models)
29	63349	Ass'y.—Side Handle
30	41332	Spring
31	54991	Pin—Spindle Lock
32	21491	Ring—Retaining
33	64046	Pinion—Spacer
34	10290	Bearing—Ball
35	28892	Armature—W/Fan
	16874	Arm & Bearing Ass'y. [Incl's. Fig's. 34 & 36]
	04321	Fan
36	10931	Bearing—Ball
37	41333-1	Finger—Spring Washer
38	2348	7" Guard [1275A & 1277A]
	2349	9" Guard [1279A]
39	06662	Screw—Pan Head (#8-32 x 1/4) (2)*
40	25059	Washer—Spacer (2)*
41	35833	Plate
42	07261	Screw—Flat HD. (#10-24 x 1/2) (2)*

\*ORDER QUANTITY AS NEEDED

Items Not Shown

20828	Plate Name (1274A)
20829	Plate Name (1275A)
20830	Plate Name (1276A)
20831	Plate Name (1277A)
20832	Plate Name (1279A)

This pdf incorporates the following model numbers:

1274A, 1275A, 1276, 1277A, 1279A