



Model 5263 Short Needle Scaler



IMPORTANT

Read these instructions carefully before installing, operating, servicing or repairing this tool. Keep these instructions in a safe accessible place.

SAFETY MESSAGES	
	Personal Safety Equipment
Use - Safety Glasses	YES
Use - Safety Gloves	YES
Use - Safety Boots	
Use - Breathing Masks	YES
Use - Ear Protectors	YES

WARNING	
	Always Read Instructions Before Using Power Tools
	Always Wear Safety Goggles
	Wear Hearing Protection
	Avoid Prolonged Exposure To Vibration

Operator Instructions

Includes:
Safety Rules
Work Stations
Foreseen Use
Putting Into Service
Operating
Dismantling and Assembly.

Safety rules when using a 5263 Needle Scaler

- Always wear safety goggles.
- Prolonged exposure to vibration may cause injury.
- Read all instructions before using this tool. All operators must be fully trained in its use and aware of these safety rules.
- Do not exceed the maximum working air pressure.
- Use personal protection equipment as recommended.
- Some dust created by power sanding, sawing, grinding, drilling, and other construction activities contains chemicals known to cause cancer, birth defects and other reproductive harm.
- Use compressed air only at the recommended conditions.
- If the tool appears to malfunction remove from use immediately and arrange for service and repair. If it is not practical to remove tool from service, then shut off the air supply to the tool and write or have written a warning note and attach it to the tool.
- If tool is to be used with a balancer or other suspension device, ensure that the tool is firmly attached to the suspension support device.
- When operating the tool, always keep the body and particularly the hands away from the working attachment fixed to the tool.
- The tool is not electrically insulated. Never use the tool if there is any chance of coming into contact with live electricity.
- Always when using the tool, adopt a firm footing and/or position and grip the tool sufficiently only to overcome any reaction forces that may result from the tool doing work. Do not overgrip.
- Use only correct spare parts for maintenance and repair. Do not improvise or make temporary repairs. Major servicing and repairs should only be carried out by persons trained to do so.
- Do not lock, tape, wire, etc. the 'On/Off' valve in 'On' position. The throttle trigger/lever, etc. must always be free to return to the 'Off' position when released.
- Always shut off the air supply to the tool and press the 'On/Off' valve to exhaust the air from the feed hose before fitting, removing or adjusting the working attachment fitted to the tool.
- Before using the tool, make sure that a shut off device has been fitted to the supply line and the position is known and easily accessible so that the air supply to the tool can be shut off in an emergency.
- Check hose and fittings regularly for wear.
- Take care against entanglement of the moving parts of the tool with clothing, hair, ties, cleaning rags, rings, jewelry, watches, bracelets, etc. This could cause the body or parts of the body to be drawn towards and in contact with the moving parts of the tool and could be very dangerous.
- It is expected that users will adopt safe working practices and observe all local, regional or country legal requirements when installing, using or maintaining the tool.
- Take care that the exhaust air does not point towards any other person or material or substance that could be contaminated by oil droplets. When first lubricating a tool or if the tool exhaust has a high oil content, do not allow the exhaust air to come near very hot surfaces or flames.
- Never lay the tool down until the working attachment has stopped moving.
- When the tool is not in use, shut off the air supply and press throttle trigger/lever to drain the supply line. If the tool is not to be used for a period of time, first lubricate, disconnect from air supply and store in a dry average room temperature environment.
- If the tool is passed from one user to a new or inexperienced user, make sure these instructions are available to be passed with the tool.
- Do not remove any manufacturer fitted safety devices where fitted, i.e., wheel guards, safety trigger, speed governors, etc.
- Wherever possible, secure workpiece with clamps, a vise, etc. to make it rigid so it does not move during the work operation. Keep good balance at all times. Do not stretch or overreach.
- Try to match the tool to the work operation. Do not use a tool that is too light or heavy for the work operation. If in doubt, seek advice.
- In general terms, this tool is not suitable for underwater use or use in explosive environments - seek advice from manufacturer.
- Try to make sure that the work area is clear to enable the work task to be performed safely. If practical and possible, try to clear unnecessary obstructions before starting work.
- Always use air hose and couplings with minimum working pressure ratings at least 1 1/2 times the maximum working pressure rating of the tool.

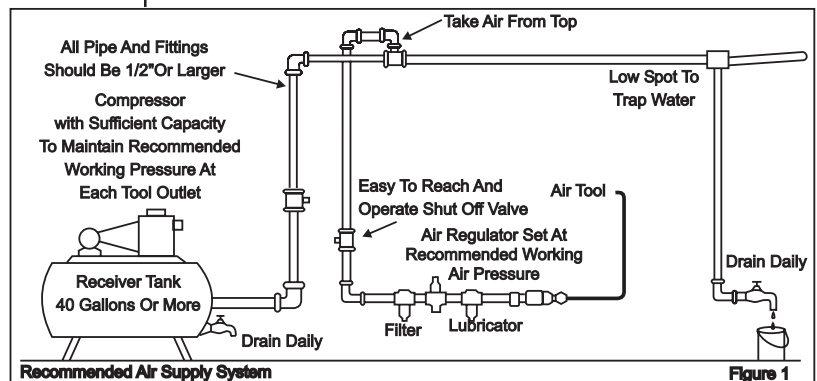

Foreseen Use Of The Tool -5263

This tool is designed for the purposes of cleaning and restoring stone and concrete, etc. and for cleaning and particularly removing paint and rust, etc. from metals. The tool is powered by a free oscillating piston, which strikes a needle holder containing several hardened needles. The needles have some free movement, which allows the tool to clean around irregular shaped surfaces. Do not use the tool for any other purposes than that for which it was designed. Do not modify the tool for any other purpose than that for which it was designed even for its purpose as a needle scaler, unless first agreeing any such alternative use or modifications, with the manufacturer or an authorized representative. The main applications for the tool is cleaning, deslagging and shot peening of welded joints, cleaning metal surfaces of rust, scale and paint, cleaning castings, removing cores, cleaning brick and stonework and cleaning ship plates, barges and buoys.

Work Stations

The tool should only be used as a handheld, hand operated tool. It is always recommended that the tool is used when standing on a solid floor. It can be used in other positions, but before any such use, the operator must be in a secure position having a firm grip and footing and be aware of the extra safety precautions that must be observed when using a needle scaler.

Putting Into Service

Air Supply

Use a clean lubricated air supply that will give a measured air pressure at the tool of 90 PSIG (6.2 bar) when the tool is running with the trigger/lever fully depressed. Use recommended hose size and length. It is recommended that the tool is connected to the air supply as shown in figure 1. Do not connect the tool to the air line system without incorporating an easy to reach and operate air shut off valve. The air supply should be lubricated. It is strongly recommended that an air filter, regulator, lubricator (FRL) is used as shown in Figure 1 as this will supply clean, lubricated air at the correct pressure to the tool. Details of such equipment can be obtained from your supplier. If such equipment is not used, then the tool should be lubricated by shutting off the air supply to the tool, depressurizing the line by pressing the trigger on the tool. Disconnect the air line and pour into the hose adaptor a teaspoonful (5ml) of a suitable pneumatic motor lubricating oil preferably incorporating a rust inhibitor. Reconnect tool to air supply and run tool slowly for a few seconds to allow air to circulate the oil. If tool is used frequently, lubricate on daily basis and if tool starts to slow or lose power. It is recommended that the air pressure at the tool while the tool is running is 90 PSI/6.2 bar.

Operating

Connect tool to a suitable air supply after having adjusted the position of the front needle cover, so that the needles project from the front end of the tool by the required amount, When using the tool, keep the tool loaded sufficiently to do the work. Do not overload the tool as this will reduce the power. Never operate the throttle lever unless the needles are in contact with the working surface. Do not run the tool unless the retainer is fitted. Always use correct size needles to match the tool. Do not store needles at freezing or below freezing temperatures as this can make hardened steel tools brittle, which can cause breakage and lead to serious injury. Do not continue to use the tool with broken needles as this may damage the tool. Be aware that needles worn/blunt at cutting edge should not be used as such conditions promote tool breakage, reduce efficiency and increase vibration. NOTE: Use only suitable pneumatic tool lubricants.

Dismantling & Assembly Instructions

Disconnect tool from air supply.

Unscrew 2 cap screws (22) with washers (23) and unscrew, pull off front tube (21) and intermediate tube (20) with spring (19), needles (18), needle holder (17) and anvil (16). Unscrew cylinder (10) with O-rings (11) and (12) from body (13). Remove piston (9) from cylinder (10). Drive out roll pin (8) and take off lever (7). Unscrew valve cap (1) with O-ring (2) and take out valve spring (3), valve stem (4) and O-ring valve seat (5). Valve body (6) may be unscrewed from and rubber handle grip (15) removed from housing (13), if replacements are required.

Reassembly

Clean all parts and examine for wear. Replace any parts with parts obtained from the manufacturer or an authorized distributor. Lightly coat all parts with a suitable pneumatic tool lubricating oil and assemble in reverse order.



5263

Short Needle Scaler

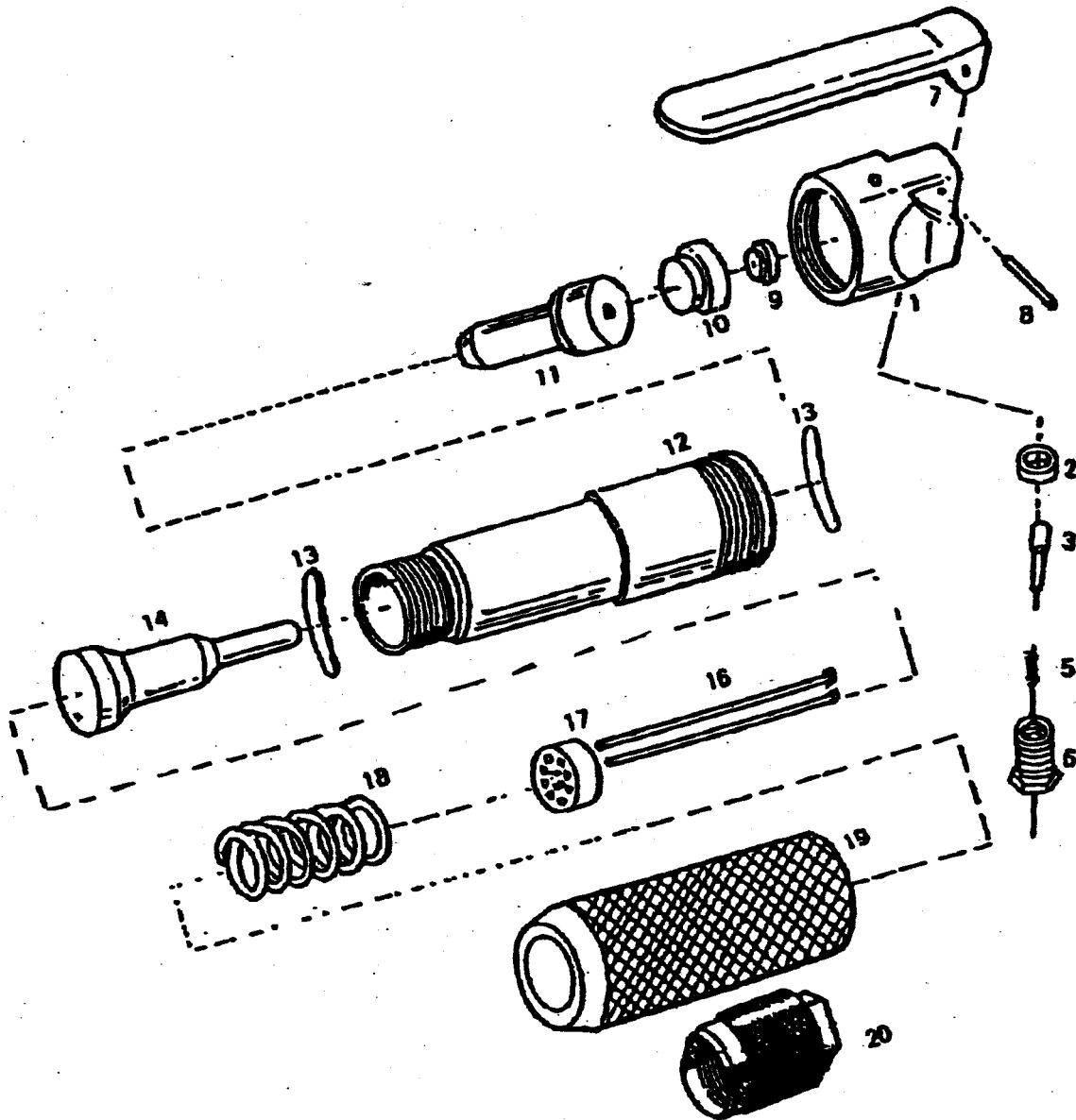

Ret No.	Part No	Description
1	505510	Backhead
2	505511	O-Ring
3	505512	Valve
5	505513	Spring
6	505514	Valve Cap
7	505515	Lover
8	505516	Pin
9	505517	Rubber Cushion

Ref. No.	Part No.	Description
10	505518	Rear Valve Block
11	505519	Mon
12	505520	Barrel Sleeve
13	505521	O-Ring (2)*
14	505522	Needle Driver
16	2259	Needle (Set of 12)
17	505523	Needle Holder
18	505524	Spring
19	505525	Needle Tube
	505488	Warning Label (Not Shown)

*Order Quantity As Required

Operation Specification	
Average Air Consumption	6 cfm (43 scfm)
Stroke	0.62" (16mm)
Air Inlet Thread	1/4-18NPT
Overall Length	11.4" (290mm)
at 90 PSIG/6.2 bar	





Other Data	
Piston Diameter	18 x 14 x 47mm
Number Of Needles	12
Needle Diameter	3mm
Needle Length	1/4-18NPT
Overall Length	125mm

NOTES

Manufacturer/Supplier Sioux Tools, Inc. 250 Snap-on Drive Murphy, NC 28906 U.S.A. Tel No. 828-835-9765 Fax No. 828-835-9685	Product Type Short Needle Scaler	RPM 4,000 Cycles Per min.
	Model No/Nos 5263	Serial No.

Product Net Weight 2.62 lbs 1.19 Kg	Recommended Use Of Balancer Or Support NO	Recommended Hose Bore Size - Minimum 3/8 Ins 10 M/M	Recommended Max. Hose Length 30 Ft 10 M
--	--	---	---

Air Pressure Recommended working 6.2 bar 90 PSI Maximum 6.2 bar 90 PSI	Noise Level: Sound Pressure Level 85.6 dB(A) Sound Power Level 97.5 dB(A) Test Method: Tested In accordance with Pneurop test code PN8NTC1 and ISO Standard 3744
---	---

SAFETY MESSAGES <small>Personal Safety Equipment</small> Use - Safety Glasses YES Use - Safety Gloves YES Use - Safety Boots Use - Breathing Masks YES Use - Ear Protectors YES	WARNING  Always Read Instructions Before Using Power Tools  Always Wear Safety Goggles  Wear Hearing Protection  Avoid Prolonged Exposure To Vibration	Vibration Level 6.67 Meters / Sec² Test Method: Tested in accordance with ISO standards 8662 Part 1
--	---	--

Declaration of Conformity
Sioux Tools Inc.
250 Snap-on Drive, P.O. Box 1596, Murphy, NC 28906, U.S.A.
declare under our sole responsibility that the product
Model 5263 Short Needle Scaler, Serial Number
to which this declaration relates is in conformity with the following standard(s) or other normative documents(s)
EN792 (Draft), EN292 Parts 1 & 2, ISO 8662 Part 1 & 12, Pneurop PN8NTC1
following the provisions of **89/392/EEC as amended by 91/368/EEC & 93/44/EEC Directives**

Mark S. Pezzoni (President Power and Specialty Tools)

Name and signature or equivalent marking of authorized person