

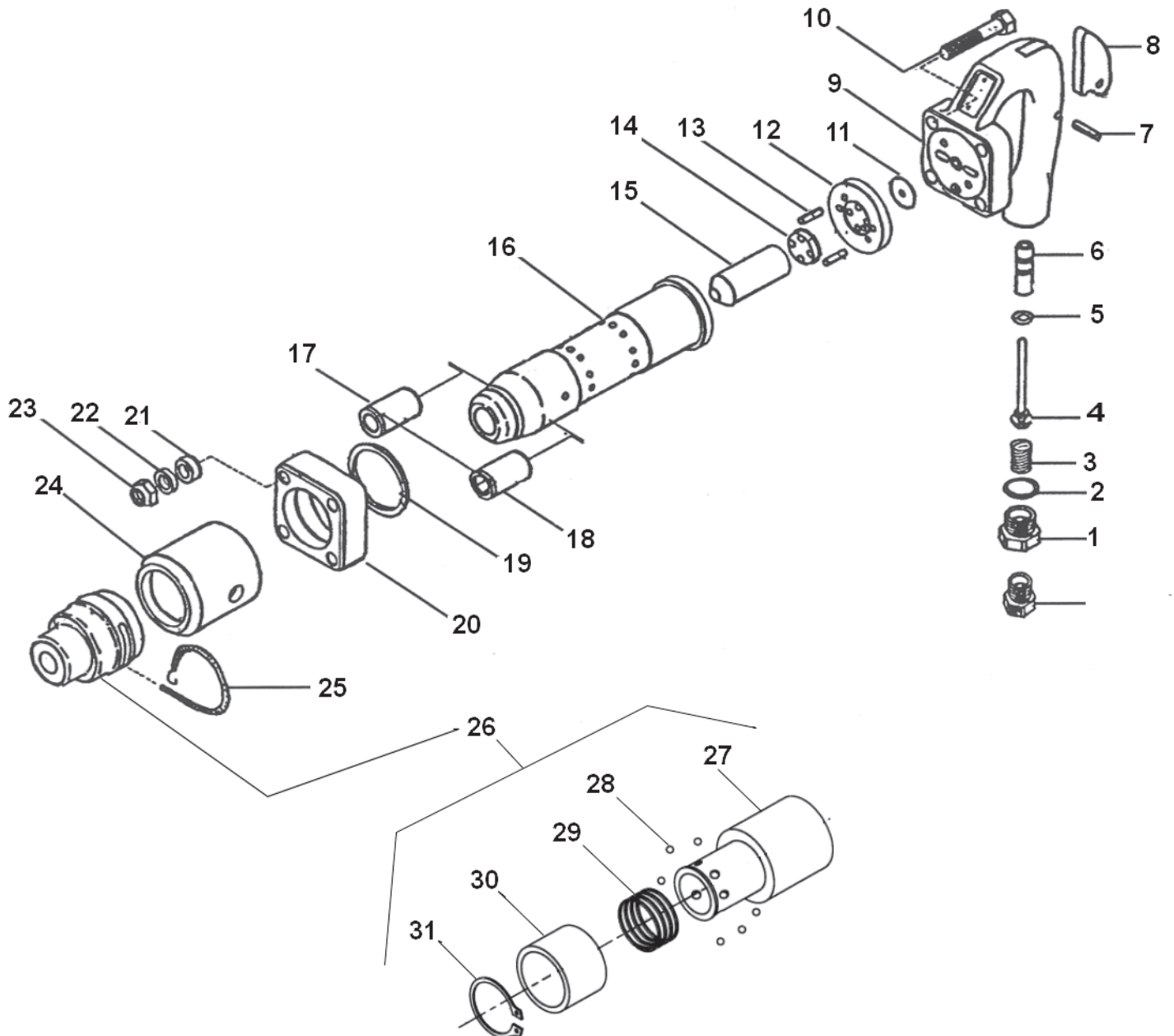

# PARTS LIST FOR 4-BOLT CHIPPER CH4



# SIoux TOOLS INC.

250 SNAP-ON DRIVE ■ PO BOX 1596 ■ MURPHY, NC 28906 ■ USA ■

Printed In U.S.A.



## PARTS LIST FOR 4-BOLT CHIPPER CH4

Fig. No.	Part No.	Description
1.	602315	Inlet Bushing
2.	602316	O-Ring
3.	602317	Throttle Valve Spring
4.	602318	Throttle Valve
5.	602319	O-Ring
6.	602320	Throttle Valve Stem Bushing
7.	602321	Throttle Lever Pin
8.	602322	Trigger
9.	602323	Handle
10.	602324	Bolt (4)*
11.	602325	Valve
12.	602326	Valve Seat
13.	602327	Valve Locator Pin (2)*
14.	602328	Valve Seat Bumper
15.	602329	Piston 2" (CH42)
15.	602330	Piston 3" (CH43)
15.	602331	Piston 4" (CH44)
16.	602332	Barrel 2" (CH42)
16.	602333	Barrel 3" (CH43)
16.	602334	Barrel 4" (CH44)
17.	602335	Round Front End Bushing (Suffix "R" Models)
18.	602336	Hex Front End Bushing (Suffix "H" Models)
19.	602337	Absorber Ring
20.	602338	Barrel Flange
21.	602339	Vibration Spacer (4)*
22.	602340	Bolt Spacer (4)*
23.	602341	Lock Nut (4)*
24.	602342	Exhaust Deflector
26.	2470	Quick Change Retainer
25.	602349	Retainer Lock Spring
27.	602343	Body
28.	602344	Ball (6)*
29.	602345	Spring
30.	602346	Sleeve
31.	602347	Retaining Ring

Not Shown  
1641HW Hose Whip Assembly

FURNISH CATALOG, SERIAL, AND MODEL NUMBER  
WHEN ORDERING PARTS

\*Order Quantity As Required

**SIoux  
TOOLS INC.**

250 SNAP-ON DRIVE ■ PO BOX 1596 ■ MURPHY, NC 28906 ■ USA ■

Printed In U.S.A.

This pdf incorporates the following model numbers:

CH42A-H

CH42A-R

CH43A-H

CH43A-R

CH44A-H

CH44A-R