



Model 5980 Air Engraving Pen

Form # Z656
Date 3-01/A



Operator Instructions Includes – Foreseen Use, Work Stations, Putting Into Service, Operating, Dismantling, Assembly and Safety Rules.		Important Read these instructions carefully before installing, operating, servicing or repairing this tool. Keep these instructions in a safe accessible place.	
Manufacturer/Supplier Sioux Tools Inc. 2901 Floyd Boulevard P.O. Box 507 Sioux City, IA 51102 U.S.A. Tel No. 712-252-0525 Fax No. 712-252-4267		Product Type Air Engraving Pen	BPM 13,000 Cycles Per Min.
		Model No/Nos 5980	Serial No.
Product Net Weight 0.48 lbs 0.22 Kg	Recommended Use Of Balancer Or Support NO	Recommended Hose Bore Size – Minimum 1/4 ins 8 M/M	Recommended Max. Hose Length 30 Ft 10 M
Air Pressure Recommended Working Maximum		6.2 bar 90 PSI 6.2 bar 90 PSI	Noise Level: Sound Pressure Level 78.0 dB(A) Sound Power Level 90.0 dB(A) Test Method: Tested in accordance with Pneurop test code PN8NTC1 and ISO Standard 3744
SAFETY MESSAGES Personal Safety Equipment Use – Safety Glasses YES Use – Safety Gloves YES Use – Safety Boots Use – Breathing Masks Use – Ear Protectors YES	WARNING 	Vibration Level Less than 2.0 Meters / Sec² Test Method: Tested in accordance with ISO standards 8662 Part 1	

Safety rules when using a 5980 Air Engraving Pen

- Prolonged exposure to vibration may cause injury.
- Read all instructions before using this tool. All operators must be fully trained in its use and aware of these safety rules.
- Do not exceed the maximum working air pressure.
- Use personal protection equipment as recommended.
- Use only compressed air at the recommended conditions.
- If the tool appears to malfunction, remove from use immediately and arrange for service and repair. If it is not practical to remove tool from service, then shut off the air supply to the tool and write or have written a warning note and attach it to the tool.
- If tool is to be used with a balancer or other suspension device, ensure that the tool is firmly attached to the suspension/support device.
- When operating the tool, always keep the body and particularly the hands away from the working attachment fixed to the tool.
- The tool is not electrically insulated. Never use the tool if there is any chance of coming into contact with live electricity.

- Always when using the tool, adopt a firm footing and/or position and grip the tool sufficiently only to overcome any reaction forces that may result from the tool doing work. Do not overgrip.
- Use only correct spare parts for maintenance and repair. Do not improvise or make temporary repairs. Major servicing and repairs should only be carried out by persons trained to do so.
- Do not lock, tape, wire, etc. the 'On/Off' valve in 'On' position.
- Always shut off the air supply to the tool and open the air regulator to exhaust the air from the feed hose before fitting, removing or adjusting the working attachment fitted to the tool.
- Before using the tool, make sure that a shut off device

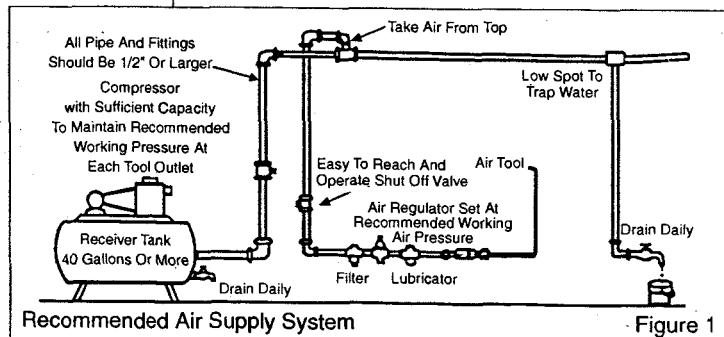

Recommended Air Supply System

Figure 1

Some dust created by power sanding, sawing, grinding, drilling, and other construction activities contains chemicals known to cause cancer, birth defects or other reproductive harm.

has been fitted to the air supply line and the position is known and easily accessible so that the air supply to the tool can be shut off in an emergency.

- Check hose and fittings regularly for wear.
- Take care against entanglement of the moving parts of the tool with clothing, hair, ties, cleaning rags, rings, jewelry, watches, bracelets, etc. This could cause the body or parts of the body to be drawn towards and in contact with the moving parts of the tool and could be very dangerous.
- It is expected that users will adopt safe working practices and observe all local, regional and country legal requirements when installing, using or maintaining the tool.
- Take care that the exhaust air does not point towards any other person or material or substance that could be contaminated by oil droplets. When first lubricating a tool or if the tool exhaust has a high oil content, do not allow the exhaust air to come near very hot surfaces or flames.
- Never lay the tool down until the working attachment has stopped moving.
- When the tool is not in use, shut off the air supply and open the air regulator to drain the supply line. If the tool is not to be used for a period of time, first lubricate, disconnect from air supply and store in a dry average room temperature environment.
- If the tool is passed from one user to a new or inexperienced user, make sure these instructions are passed with the tool.
- Do not remove any manufacturer fitted safety devices where fitted, i.e., wheel guards, safety trigger, speed governors, etc.
- Wherever possible, secure workpiece with clamps, a vise, etc. to make it rigid so it does not move during the work operation. Keep good balance at all times. Do not stretch or overreach.
- Try to match the tool to the work operation. Do not use a tool that is too light or heavy for the work operation. If in doubt, seek advice.
- In general terms, this tool is not suitable for underwater use or use in explosive environments — seek advice from manufacturer.
- Try to make sure that the work area is clear to enable the work task to be performed safely. If practical and possible, try to clear unnecessary obstructions before starting work.
- Always use air hose and couplings with minimum working pressure ratings at least 1 1/2 times the maximum working pressure rating of the tool.

Foreseen Use Of The Tool – 5980

This Air Engraving Pen is designed to permanently etch into most industrial materials. It is commonly used to write on hardened steel plating up to a hardness of HRC55, metal, glass, stones, ceramic, plastics and a host of other type surfaces. This tool may also be used for deburring, reshaping the cut on a screw head or broken bolt for easier removal. The most common use is to personalize various tools, machinery and equipment in the workplace. Do not use the tool for any other purpose than afore mentioned unless first seeking the advice of the manufacturer or the manufacturer's authorized representative. Do not modify the tool even to be used as an engraver.

Work Stations

The tool should only be used as a handheld, hand operated tool. It is always recommended that the tool is used when standing on a solid floor. It can be used in other positions, but before any such use, the operator must be in a secure position having a firm grip and footing and be aware of the extra safety precautions that must be observed when using grinding machines.

Putting Into Service

Air Supply

Use a clean lubricated air supply that will give a measured air pressure at the tool of 90 p.s.i./6.2 bar when the tool is running with the air regulator fully open. Use recommended hose size and length. It is recommended that the tool is connected to the air supply as shown in figure 1. Do not connect the tool to the air line system without incorporating an easy to reach and operate air shut off valve. The air supply should be lubricated. It is strongly recommended that an air filter, regulator, lubricator (FRL) is used as shown in Figure 1 as this will supply clean, lubricated air at the correct pressure to the tool. Details of such equipment can be obtained from your supplier. If such equipment is not used, then the tool should be lubricated by shutting off the air supply to the tool, depressurizing the line by opening the air regulator on the tool. Disconnect the air line and pour into the hose adaptor a teaspoonful (5ml) of a suitable pneumatic motor lubricating oil preferably incorporating a rust inhibitor. Reconnect tool to air supply and run tool slowly for a few seconds to allow air to circulate the oil. If tool is used frequently, lubricate on daily basis and if tool starts to slow or lose power.

It is recommended that the air pressure at the tool while the tool is running is 90 psi/6.2 bar.

Operating

For best results, hold the tool firmly by the knurled portion of the nose (2) and at a natural angle to the working surface, much as one would hold a pencil. Open the throttle valve fully by holding the throttle valve (3) securely and turning the tool clockwise until the tool stops. This will provide maximum power at the impact point. NOTE: Do not force the tool as this might damage internal o-rings. The impact force may be adjusted for various surfaces by holding securely the throttle valve and turning the tool counterclockwise toward the OFF position.

Although the tool comes with an engraving needle for a thick plate, optional needles may be purchased for engraving medium and thin plates. To change needle, secure the body (1) in a vise fitted with soft jaws and unscrew nose (2). Using a rubber hammer, tap out needle guide (6) and replace the needle as desired.

Lubricate pen daily, or each time used, using a light mineral oil, free from acids, carbon or gummy residue. It is recommended that the lubricant used has a viscosity of 1.7 + 3.3 E/50° C (122° F).

Dismantling & Assembly Instructions

Disconnect tool from air supply.

Secure the knurled portion of the throttle valve (3) in a vise or hold with pliers fitted with soft jaws. Then, using the proper sized wrench, unscrew air inlet hose (11) from the throttle valve (3). Secure knurled portion of nose (2) in a vise fitted with soft jaws and unscrew ring nut (4). Unscrew throttle valve (3) and separate o-ring (10), seal (8), valve seat (5), from body (1). Unscrew nose (2) from body (1) and separate o-ring (7), engraving needle (14), and spring (9) from nose (2). Remove o-ring (15) from needle guide (6). Using a rubber hammer, firmly tap head of needle guide (6) separating it from nose (2).

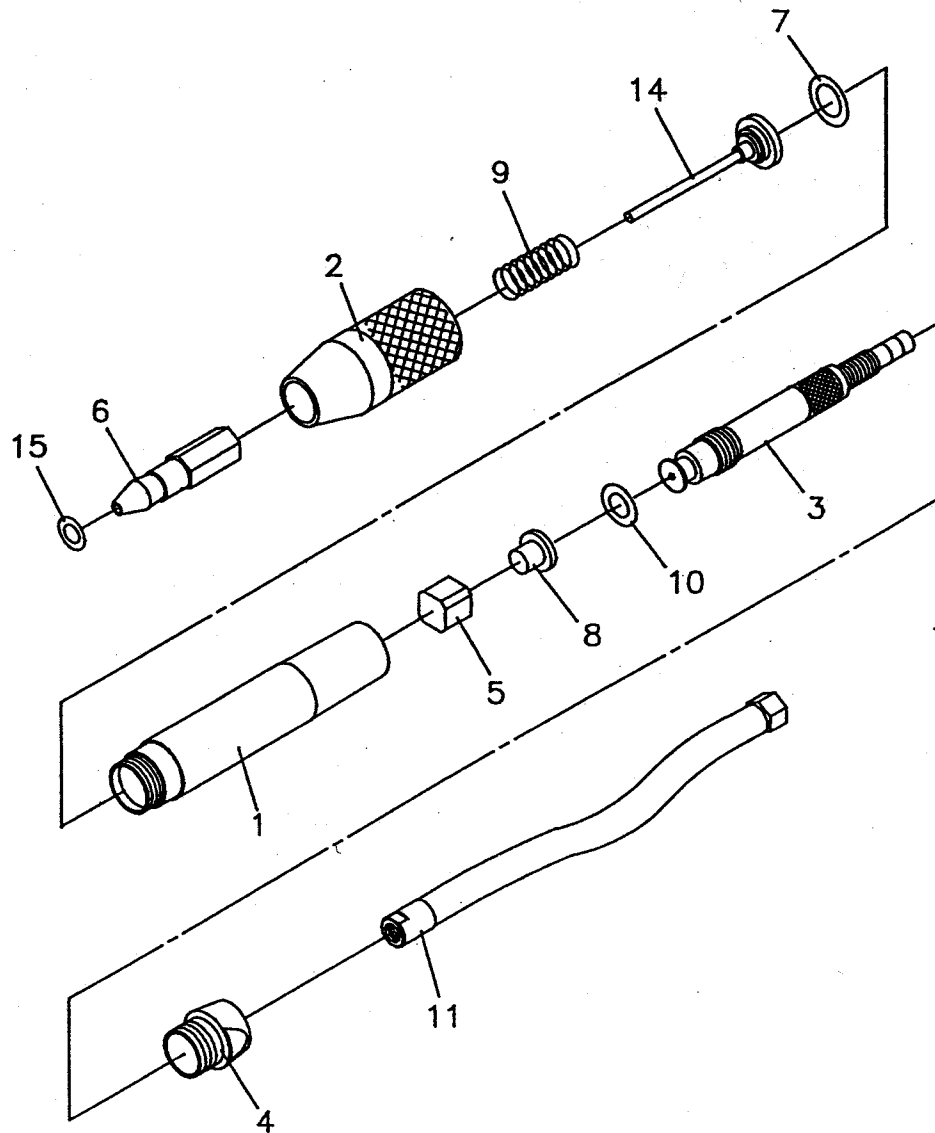

Ref. No.	Part No.	Description
1	506232	Body
2	506234	Nose
3	506235	Throttle Valve
4	506236	Ring Nut
5	506237	Valve Seat
6	506238	Needle Guide
7	506239	O-Ring (P8)
8	506240	Seal

Ref. No.	Part No.	Description
9	506241	Spring
10	506242	O-Ring (5.2 x 2.6 mm)
11	506243	Black Hose with Air Inlet
14	506246	Engraving Needle (Thick Plate) (45°)
15	506266	O-Ring (5 x 1.8 mm)
Not Shown	506244	Engraving Needle Thin Plate (15°) (opt.)
Not Shown	506245	Engraving Needle Medium Plate (30°) (opt.)
Not Shown	67411	Warning Label Icon

Reassembly

Clean all parts and examine for wear, replacing any worn or damaged parts. Make sure needle guide (6) is free from burrs before reassembling. Use only replacement parts obtained from the manufacturer or an authorized distributor. Lightly coat all parts with a suitable mineral oil as noted in "Operating" section and assemble the tool in reverse order.

Operation Specification	
Average Air Consumption	1.0 cfm (7 scfm)
Air Inlet Thread	1/4-18NPT
Length Without Hose	5.5" (140mm)
Hose Length w/Air Inlet	59.5" (1,511 mm)
Capacity	Steel Plate w/Hardness HRC55
at 90 PSIG/6.2 bar	

Notes

Notes