



Model 5287A

7" Dia. Pad Right Angle Sander

Form # Z467
Date 2-02/B



IMPORTANT

Read these instructions carefully before installing, operating, servicing or repairing this tool. Keep these instructions in a safe accessible place.

SAFETY MESSAGES		WARNING	Operator Instructions
Personal Safety Equipment			Includes: Safety Rules Foreseen Use Work Stations Putting into Service Operating Dismantling and Assembly.
Use – Safety Glasses	YES	Always Read Instructions Before Using Power Tools	
Use – Safety Gloves	YES	Always Wear Safety Goggles	
Use – Safety Boots		Wear Hearing Protection	
Use – Breathing Masks	YES	Avoid Prolonged Exposure To Vibration	
Use – Ear Protectors			

Safety rules when using a 5287A Sander

- Do not use the tool as a grinder.
- Do not use polystyrene pads.
- For Sander, use accessories rated at least 6,000 RPM.
- Prolonged exposure to vibration may cause injury.
- Read all instructions before using this tool. All operators must be fully trained in its use and aware of these safety rules.
- Do not exceed the maximum working air pressure.
- Use personal protection equipment as recommended.
- Some dust created by power sanding, sawing, grinding, drilling, and other construction activities contains chemicals known to cause cancer, birth defects and other reproductive harm.
- Use compressed air only at the recommended conditions.
- If the tool appears to malfunction, remove from use immediately and arrange for service and repair. If it is not practical to remove tool from service, then shut off the air supply to the tool and write or have written a warning note and attach it to the tool.
- If tool is to be used with a balancer or other suspension device, ensure that the tool is firmly attached to the suspension/support device.
- When operating the tool, always keep the body and particularly the hands away from the working attachment fixed to the tool.
- The tool is not electrically insulated. Never use the tool if there is any chance of coming into contact with live electricity.
- Always when using the tool, adopt a firm footing and/or position and grip the tool sufficiently only to overcome any reaction forces that may result from the tool doing work. Do not overgrip.
- Use only correct spare parts for maintenance and repair. Do not improvise or make temporary repairs. Major servicing and repairs should only be carried out by persons trained to do so.
- Do not lock, tape, wire, etc. the 'On/Off' valve in 'On' position. The throttle trigger/lever, etc. must always be free to return to the 'Off' position when released.
- Always shut off the air supply to the tool and press the 'On/Off' valve to exhaust the air from the feed hose before fitting, removing or adjusting the working attachment fitted to the tool.
- Before using the tool, make sure that a shut off device has been fitted to the supply line and the position is known and easily accessible so that the air supply to the tool can be shut off in an emergency.
- Check hose and fittings regularly for wear.
- Take care against entanglement of the moving parts of the tool with clothing, hair, ties, cleaning rags, rings, jewelry, watches, bracelets, etc. This could cause the body or parts of the body to be drawn towards and in contact with the moving parts of the tool and could be very dangerous.
- It is expected that users will adopt safe working practices and observe all local, regional or country legal requirements when installing, using or maintaining the tool.
- Take care that the exhaust air does not point towards any other person or material or substance that could be contaminated by oil droplets. When first lubricating a tool or if the tool exhaust has a high oil content, do not allow the exhaust air to come near very hot surfaces or flames.
- Never lay the tool down until the working attachment has stopped moving.
- When the tool is not in use, shut off the air supply and press throttle trigger/lever to drain the supply line. If the tool is not to be used for a period of time, first lubricate, disconnect from air supply and store in a dry average room temperature environment.
- If the tool is passed from one user to a new or inexperienced user, make sure these instructions are available to be passed with the tool.
- Do not remove any manufacturer fitted safety devices where fitted, i.e., wheel guards, safety trigger, speed governors, etc.
- Wherever possible, secure workpiece with clamps, a vise, etc. to make it rigid so it does not move during the work operation. Keep good balance at all times. Do not stretch or overreach.
- Try to match the tool to the work operation. Do not use a tool that is too light or heavy for the work operation. If in doubt, seek advice.
- In general terms, this tool is not suitable for underwater use or use in explosive environments — seek advice from manufacturer.
- Try to make sure that the work area is clear to enable the work task to be performed safely. If practical and possible, try to clear unnecessary obstructions before starting work.
- Always use air hose and couplings with minimum working pressure ratings at least 1 1/2 times the maximum working pressure rating of the tool.

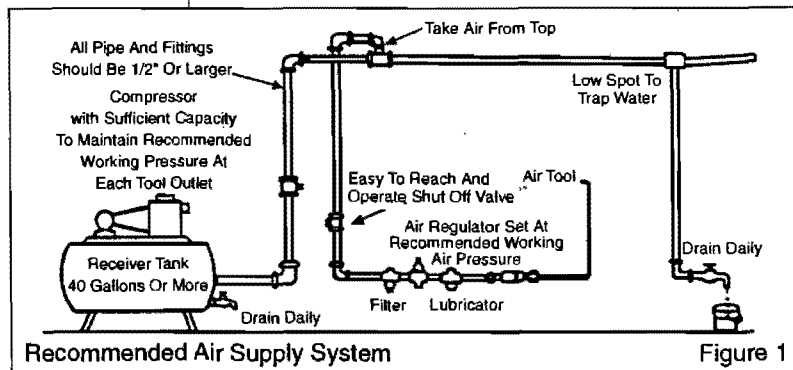

Foreseen Use Of The Tool – 5287A

This right angle tool is designed for use with 7" diameter coated abrasive discs of various grades of grit which are designed to be used at the same or higher speed of the tool. The spindle thread is 5/8-11UNC-2A and the tool can be used with other abrasive devices that have the same female thread size and are designed to run without a guard and have a rated speed equal to or higher than the speed of the tool. Do not attempt to use any bonded abrasive devices, i.e., grinding wheels, as those which could be fitted because of their size, cannot be used without a suitable guard. A guard is not available for this tool. Do not fit any form of saw blade.

Do not fit any other abrasive or cutting device before checking the suitability for use with this tool with the manufacturer or the manufacturer's authorized distributor.

Do not modify this tool for other use, or for its use as a sander before checking the intended alternative use with the manufacturer or his authorized distributor.

Work Stations

The tool should only be used as a handheld, hand operated tool. It is always recommended that the tool is used when standing on a solid floor. It can be used in other positions, but before any such use, the operator must be in a secure position having a firm grip and footing and be aware of the extra safety precautions that must be observed when using the sander.

Putting Into Service

Air Supply

Use a clean lubricated air supply that will give a measured air pressure at the tool of 90 PSIG (6.2 bar) when the tool is running with the trigger/lever fully depressed. Use recommended hose size and length. It is recommended that the tool is connected to the air supply as shown in figure 1. Do not connect the tool to the air line system without incorporating an easy to reach and operate air shut off valve. The air supply should be lubricated. It is strongly recommended that an air filter, regulator, lubricator (FRL) is used as shown in Figure 1 as this will supply clean, lubricated air at the correct pressure to the tool. Details of such equipment can be obtained from your supplier. If such equipment is not used, then the tool should be lubricated by shutting off the air supply to the tool, depressurizing the line by pressing the trigger on the tool. Disconnect the air line and pour into the hose adaptor a teaspoonful (5ml) of a suitable pneumatic motor lubricating oil preferably incorporating a rust inhibitor. Reconnect tool to air supply and run tool slowly for a few seconds to allow air to circulate the oil. If tool is used frequently, lubricate on daily basis and if tool starts to slow or lose power.

It is recommended that the air pressure at the tool while the tool is running is 90 PSI/6.2 bar. The tool can be run at lower and higher pressures with the maximum permitted working air pressure of 90 PSI/6.2 bar. The tool incorporates an air regulator to reduce the speed of the tool, if required.

Operating

Select a suitable abrasive disc (see Section "Foreseen Use Of The Tool") and make sure that it is fixed securely to the tool. Connect to suitable air supply as recommended. Make sure that the side handle is tightened securely.

Apply the sander lightly to the work and allow the abrasive disc to cut. Take great care when sanding around sharp edges and surfaces to avoid the disc snagging i.e. the disc may be brought to an abrupt stop or considerably slowed which will cause the tool to kick in the hands. It is always recommended to use safety glasses and a breathing mask. The sanding of certain materials may create a hazardous dust which may require special breathing equipment. Check before using the tool. Even if the machine has a low noise level, the actual sanding process may cause a noise level such that ear protectors will be required. If there are sharp areas on the material being sanded, safety gloves are recommended.

Do not continue to use abrasive discs that are worn or clogged. This will make the sanding process inefficient and the need to apply unnecessarily high forces to the tool.

Do not use undersized or oversized discs. The disc should be no more than 1/4" larger in diameter than the pad and not smaller than the pad.

Dismantling & Assembly Instructions

Disconnect tool from air supply.

Grip work spindle (15) with the spanner provided and grip the pad (16) and unscrew this together with pad nut (17) and abrasive sanding disc. Remove dead handle (3). Unscrew 4 cap screws (11) and take off lock washers (10) and pull out housing cap (9) with spindle assembly from motor housing (2). Take off bearing plate (4) and ball bearing (5). Remove retaining ring (6) and take off wave washer (7), bevel gear (8) and key (14). Remove retaining ring (13) from the front side of housing cap (9) and spindle with bearing. Support bearing (12) on the threaded shaft side, press non-threaded end of the spindle to release bearing and spindle. Take off housing band (28) and unscrew 4 cap screws (33) with 4 washers (10), pull out motor assembly with pinion gear (19) from motor housing (2) and take off motor gasket (29), spacer (30) with O-ring (27), valve body gasket (31) and valve housing assembly (32). Pull out pinion gear from motor assembly and press apart pinion gear (19) and bearing (20). To dismantle motor assembly, hold (grip) the motor assembly by hand and tap the splined end of rotor (22) with a non-metallic and/or soft metal hammer to drive the rotor (22) through the front end plate (21) and bearing (5) assembly. Remove bearing (5) from front plate (21) using suitable equipment. Remove cylinder (24) with roll pin (25) and 4 rotor blades (23). Do not remove roll pin (25) from cylinder (24) unless replacement is required. Take off retaining ring (18) from rear end plate (26). Supporting rear end plate (26) in a piece of tube with a bore as close as possible to the maximum diameter of the rotor (22) and tap the non-splined end of rotor through rear end plate (26) and ball bearing (5) assembly. Using a suitable punch, tap out bearing (5) from rear end plate (26).

Unscrew inlet bushing (44) with O-ring (43) and exhaust bushing (45) from valve housing assembly (32). Take apart O-ring (43), exhaust retainer (42), exhaust gasket (41), valve spring (40) and valve assembly (39) with valve pin (38).

NOTE: Do not take off valve seat (37), valve assembly (39 and 38) from valve housing (32) unless replacement is required.

Drive out lever pin (36) and take off locking lever (35) and valve pin (34).



5287A

7" Dia. Pad Right Angle Sander

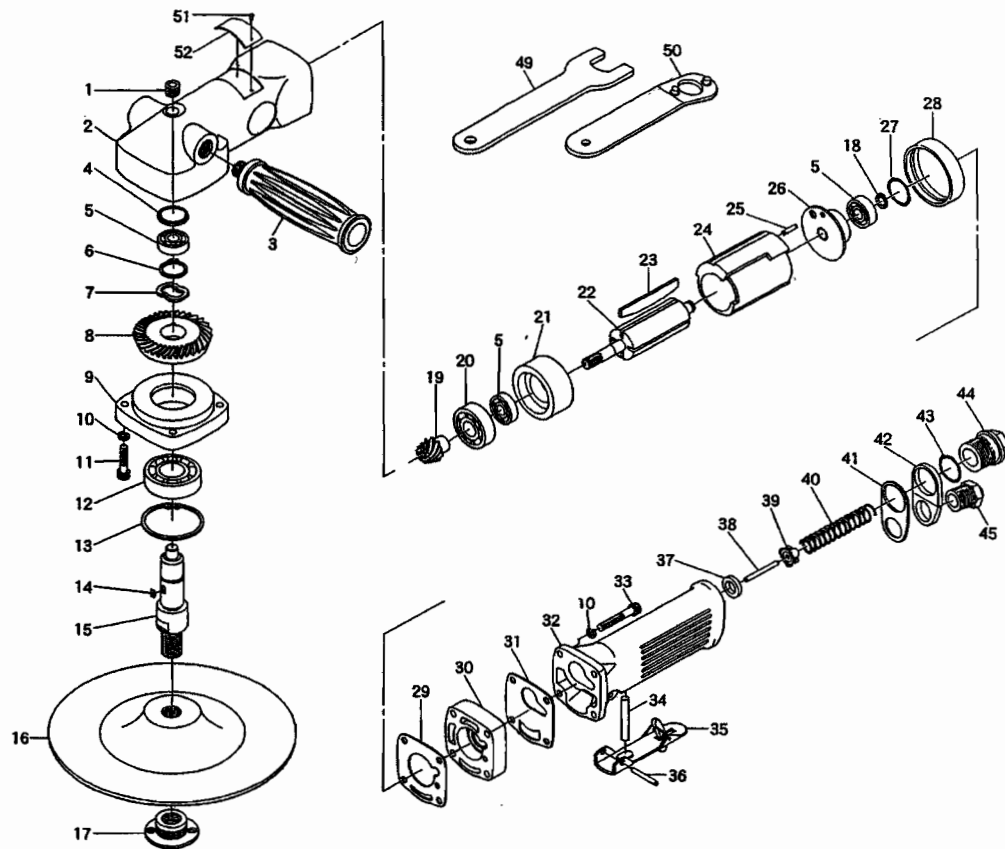

Ref. No.	Part No.	Description
1	505356	Plug
2	505357	Motor Housing
3	67728	Dead Handle
4	67729	Bearing Plate
5	67472	Ball Bearing (3)*
6	67730	Retaining Ring
7	67731	Wave Washer
8	67733	Bevel Gear
9	67738	Housing Cap
10	67713	Lockwasher (8)*
11	67739	Cap Screw (4)*
12	67740	Ball Bearing
13	67741	Retaining Ring
14	67734	Key
15	67735	Work Spindle
16	5207	7" Backing Pad (included #17 nut)
17	67630	Pad Nut
18	67716	Retaining Ring (2)*
19	67726	Pinion Gear
20	67724	Ball Bearing
21	67723	Front End Plate
22	67720	Rotor
23	67718	Rotor Blade (Set of 4)
24	67722	Cylinder
25	67337	Spring Pin
26	67717	Rear End Plate

Ref. No.	Part No.	Description
27	505358	O-Ring
28	67743	Housing Band
29	505359	Motor Gasket
30	505360	Spacer
31	505361	Valve Body Gasket
32	505362	Valve Housing
33	505363	Cap Screw (4)*
34	505364	Valve Pin
35	67662	Locking Lever
36	66540	Lever Pin
37	505365	Valve Seat
38	505366	Valve Pin
39	505367	Valve
40	505368	Valve Spring
41	505369	Exhaust Gasket
42	505370	Exhaust Retainer
43	505371	O-Ring
44	505372	Inlet Bushing
45	505373	Exhaust Bushing
49	67672	Spindle Wrench
50	67673	Spanner Wrench
51	66580	Name Plate Screw (2)*
52	505375	Name Plate
Not Shown	SP67536	Pad Warning Label for 5207
Not Shown	SP67500	Warning Label

*Order Quantity as Needed



Reassembly

Clean all parts and examine for wear. Use only distributor or manufacturer supplied replacement parts. Check carefully in particular for wear and tears of O-rings and rotor blades. Lightly coat all parts with a suitable pneumatic tool lubricating oil, one preferably containing an rust inhibitor and reassemble in the reverse order.

Operation Specification	
Air Consumption	4.8 cfm
Spindle Thread	5/8-11UNC
Disc Size	4 1/2" (115mm)
Air Inlet Thread	1/4-18NPT
Overall Length	12.6" (320mm)
at 90 PSIG	

NOTES

NOTES

Manufacturer/Supplier Sioux Tools, Inc. 117 Levi Drive Murphy, NC 28906 U.S.A. Tel No. 828-835-9765 Fax No. 828-835-9685		Product Type 7" Dia. Pad Right Angle Sander	RPM 6,000 <small>Cycles Per Min.</small>	
		Model No/Nos 5287A	Serial No.	
Product Net Weight 4.4 lbs 2.0 Kg	Recommended Use Of Balancer Or Support NO	Recommended Hose Bore Size – Minimum 3/8 Ins 10 M/M	Recommended Max. Hose Length 30 Ft 10 M	
Air Pressure Recommended Working 6.2 bar 90 PSI Maximum 6.2 bar 90 PSI		Noise Level: Sound Pressure Level 97.0 dB(A) Sound Power Level 107.40 dB(A) Test Method: Tested in accordance with Pneurop test code PN8NTC1 and ISO Standard 3744		
SAFETY MESSAGES <small>Personal Safety Equipment</small> Use – Safety Glasses YES Use – Safety Gloves YES Use – Safety Boots Use – Breathing Masks YES Use – Ear Protectors	 WARNING Always Read Instructions Before Using Power Tools Always Wear Safety Goggles Wear Hearing Protection Avoid Prolonged Exposure To Vibration	Vibration Level Less than 2.5 Meters / Sec² Test Method: Tested in accordance with ISO standards 8662 Parts 1 & 4		

CE

Declaration of Conformity

Sioux Tools Inc.

117 Levi Drive, Murphy, NC 28906, U.S.A.

declare under our sole responsibility that the product

Model 5287A 7"Dia R/A Sander, Serial Number

to which this declaration relates is in conformity with the following standard(s) or other normative document(s)

EN792 (Draft), EN292 Parts 1 & 2, ISO 8662 Parts 1 & 4, Pneurop PN8NTC1

following the provisions of **89/392/EEC as amended by 91/368/EEC & 93/44/EEC Directives**

Gerald E. Seebeck (President)

Name and signature or equivalent marking of authorized person

This pdf incorporates the following model numbers:

5238A