

Operator Instructions

Includes - Foreseen Use, Work Stations, Putting Into Service, Operating, Dismantling, Assembly and Safety Rules

Important

Read these instructions carefully before installing, operating, servicing or repairing this tool. Keep these instructions in a safe accessible place.

Manufacturer/Supplier Sioux Tools Inc. 2901 Floyd Boulevard P.O. Box 507 Sioux City Iowa 51102 U.S.A. Tel No 712-252-0525 Fax No 712-252-4267	Product Type 10mm Belt Sander	Belt Speed 1,100M/Min	
	Model No/Nos 5561	Serial No	

Product Net Weight 1.98 lbs 0.9 Kg	Recommended Use Of Balancer Or Support No	Recommended Hose Bore Size - Minimum 3/8 Ins 10 M/M	Recommended Max. Hose Length 30 Ft 10 M
--	--	--	--

Air Pressure Recommended Working 6.2 bar 90 PSI Maximum 7.0 bar 100 PSI	Noise Level Sound Pressure Level 85.0 dB(A) Sound Power Level 96.0 dB(A) Test Method Tested in accordance with Pneurop test code PN8NTC1 and ISO Standard 3744
---	---

SAFETY MESSAGES Personal Safety Equipment Use - Safety Glasses Yes Use - Safety Gloves Use - Safety Boots Use - Breathing Masks Yes Use - Ear Protectors	<p>WARNING Always Read Instructions Before Using Power Tools Always Wear Safety Goggles Wear Hearing Protection Avoid Prolonged Exposure To Vibration</p>	Vibration Level Less than 2.5 Metres / Sec² Test Method Tested in accordance with ISO standard 8662/1
---	---	--

Safety rules when using a 5561 Sander

- Always wear safety goggles.
- Do not use as a Grinder.
- Do not use polystyrene pads.
- Use accessories rated for at least Belt Speed 1,100M/Min.
- Prolonged exposure to vibration may cause injury.
- Read all instructions before using this tool. All operators must be fully trained in its use and aware of these safety rules.
- Do not exceed the maximum working air pressure.
- Use personal protection equipment as recommended.
- Use only compressed air at the recommended conditions.
- If the tool appears to malfunction, remove from use immediately and arrange for service and repair. If it is not practical to remove the tool from service, then shut off the air supply to the tool and write or have written a warning note and attach it to the tool.
- If the tool is to be used with a balancer or other suspension device, ensure that the tool is firmly attached to the suspension/support device.
- When operating the tool, always keep the body and particularly the hands away from the working attachment fixed to the tool.

- The tool is not electrically insulated. Never use the tool if there is any chance of coming into contact with live electricity.
- Always when using the tool, adopt a firm footing and/or position and grip the tool sufficiently only to overcome any reaction forces that may result from the tool doing work. Do not overgrip.
- Use only correct spare parts for maintenance and repair. Do not improvise or make temporary repairs. Major servicing and repairs should only be carried out by persons trained to do so.
- Do not lock, tape, wire, etc. the 'On/Off' valve in 'On' position. The trigger lever, etc. must always be free to return to the 'Off' position when released.
- Always shut off the air supply to the tool and press the

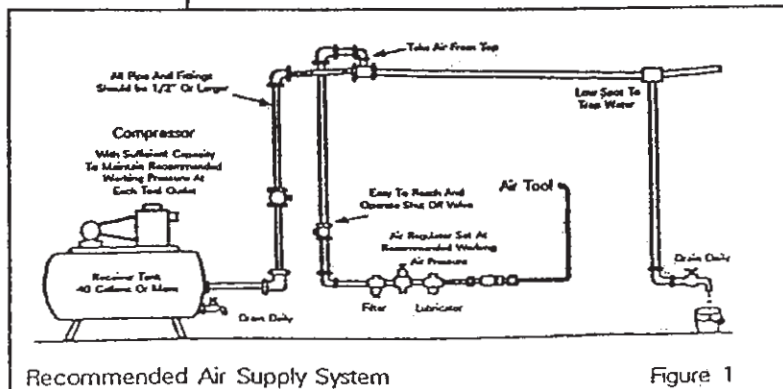

Recommended Air Supply System

Figure 1

'On/Off' valve to exhaust the air from the feed hose before fitting, removing or adjusting the working attachment fitted to the tool.

- Before using the tool make sure that a shut off device has been fitted to the supply line and the position is known and easily accessible so that the supply to the tool can be shut off in an emergency.
- Check hose and fittings regularly for wear.
- Take care against entanglement of the moving parts of the tool with clothing, hair, ties, cleaning rags, rings, jewellery, watches, bracelets, etc. This could cause the body or parts of the body to be drawn towards and in contact with the moving parts of the tool and could be very dangerous.
- It is expected that users will adopt safe working practices and observe all local, regional or country legal requirements when installing, using or maintaining the tool.
- Take care that the exhaust air does not point towards any other person or material or substance that could be contaminated by oil droplets. When first lubricating a tool or if the tool exhaust has a high oil content, do not allow the exhaust air to come near very hot surfaces or flames.
- Never lay the tool down until the working attachment has stopped moving.
- When the tool is not in use, shut off the air supply and press trigger/lever to drain the supply line. If the tool is not to be used for a period of time, first lubricate, disconnect from air supply and store in a dry average room temperature environment.
- If the tool is passed from one user to a new or inexperienced user, make sure these instructions are available to be passed with the tool.
- Do not remove any manufacturer fitted safety devices where fitted, i.e. wheel guards, safety trigger, speed governors, etc.
- Where ever possible, secure workpiece with clamps, a vise, etc. to make it rigid so it does not move during the work operation. Keep good balance at all times. Do not stretch or overreach.
- Try to match the tool to the work operation. Do not use a tool that is too light or heavy for the work operation. If in doubt, seek advice.
- In general terms this tool is not suitable for underwater use or use in explosive environments -- seek advice from manufacturer.
- Try to make sure that the work area is clear to enable the work task to be performed safely. If practical and possible, try to clear unnecessary obstructions before starting work.
- Always use air hose and couplings with minimum working pressure ratings at least 1 1/2 times the maximum working pressure rating of the tool.

Foreseen Use of the Tool

The tool is designed for the purpose of cleaning or sanding of materials using a continuous abrasive belt. Belts are available in various grades to suit fine finishing or fast material removal. Do not use the tool for any other purpose than that for which it was designed. Do not modify this tool for any other use or for its use as a belt sander without first consulting the manufacturer or the manufacturer's authorised distributor.

Work Stations

The tool should only be used as a hand held hand operated tool. It is always recommended that the tool is used when standing on a solid floor. It can be used in other positions but before any such use the operator must be in a secure position having a firm grip and footing and be aware of the safety rules to be obeyed when using the sander.

Putting Into Service

Air Supply

Use a clean lubricated air supply that will give a measured air pressure at the tool of 90 p.s.i./6.2 bar when the tool is running with the trigger/lever fully depressed. Use recommended hose size and length. It is recommended that the tool is connected to the air supply as shown in figure 1. Do not connect the tool to the air line system without incorporating an easy to reach and operate air shut off valve. The air supply should be lubricated. It is strongly recommended that an air filter, regulator, lubricator (FRL) is used as shown in Figure 1 as this will supply clean, lubricated air at the correct pressure to the tool. Details of such equipment can be obtained from your supplier. If such equipment is not used then the tool should be lubricated by shutting off the air supply to the tool, depressurising the line by pressing the trigger on the tool. Disconnect the air line and pour into the intake bushing a teaspoonful (5ml) of a suitable pneumatic motor lubricating oil preferably incorporating a rust inhibitor. Reconnect tool to air supply and run tool slowly for a few seconds to allow air to circulate the oil. If tool is used frequently lubricate on daily basis and if tool starts to slow or lose power.

It is recommended that the air pressure at the tool whilst the tool is running is 90 p.s.i./6.2 bar. The tool can run at lower and higher pressures with the maximum permitted working air pressure of 100 p.s.i./7 bar.

Operating

Select a suitable abrasive belt of the required grade to achieve a fine sanded finish or high metal removal. The belt size for this tool is 10 mm wide x 330 circumference (continuous belt) and is available in various grades, the lowest is grade 40 grit which is coarse for high material removal and grits are available as 40, 50, 60, 80, 100 and 120. The coarseness of the grit decreases as the grade number increases, hence 40 is coarse and 120 very fine.

To fit a belt, press down the stopper and push the idle pulley towards the tool until the stopper clicks into place which releases the tension and holds the tension off the belt. Fit the belt ensuring that it sits centrally on the drive pulley and the idle pulley. Release the stopper to tighten the belt. Start the tool slowly and use the adjusting screw(33) to align the belt centrally.

Apply the sander lightly to the work and allow the belt to cut. Take great care when sanding around sharp edges and corners to avoid snagging and belt damage or breakage. It is always recommended to use safety glasses and a breathing mask. The sanding of certain materials may create a hazardous dust which may require special breathing equipment. Check before using the tool.

Even if the tool has a low noise level, the actual sanding process may create a noise such that hearing protectors should be worn.

If there are sharp edges on the material being sanded then safety gloves are recommended.

Do not continue to use belts that are clogged or worn as this will make the sanding process inefficient and the need to apply unnecessarily high loads to the tool.

Only use belts of the dimensions specified. To use an incorrect belt will either cause it to break or fly off. Both occurrences could be dangerous.



5561

10mm Belt Sander

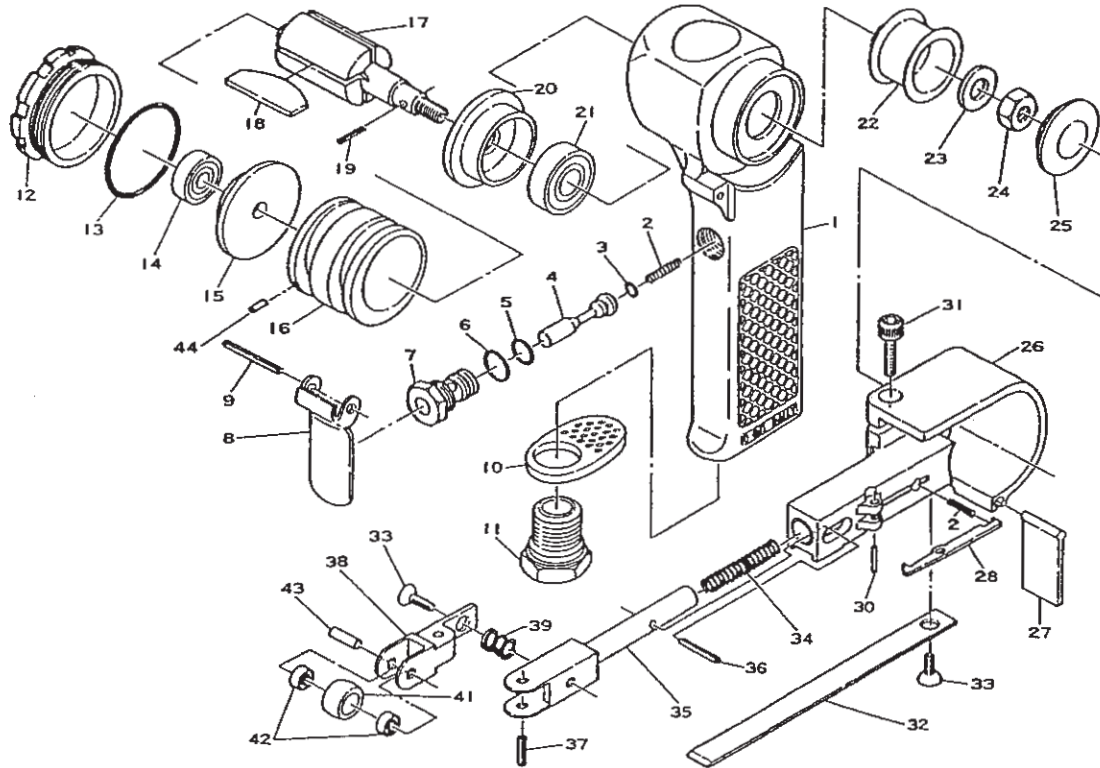

Ref No	Part No	Description
1	67356	Motor Housing
2	67314	Spring (2) *
3	67077	O-Ring
4	67315	Valve Stem
5	66600	O-Ring
6	67412	O-Ring
7	67316	Valve Body
8	67317	Throttle Lever
9	66540	Lever Pin
10	67318	Deflector
11	67319	Inlet Bushing
12	67320	Motor Nut
13	67321	O-Ring
14	66504	Ball Bearing
15	67322	Rear Plate
16	67357	Cylinder
17	67358	Rotor
18	67359	Rotor Blade (Set of 4)
19	67326	Roll Pin
20	67327	Front Plate
21	67328	Ball Bearing
22	67360	Drive Pulley
23	67361	Washer
24	67331	Lock Nut
25	67362	Pulley Cap
26	67363	Wheel Cover
27	67364	Apron
28	67365	Stopper

Ref No	Part No	Description
30	67366	Roll Pin
31	67367	Adjust Screw
32	67368	Shoe
33	67369	Screw (2) *
34	67370	Tension Spring
35	67371	Tension Arm
36	67372	Stopper Pin
37	67373	Roll Pin
38	67374	Adjust Arm
39	67375	Adjust Spring
41	67376	Idle Pulley
42	67377	Ball Bearing (2) *
43	67378	Pulley Pin
44	67332	Cylinder Pin
		Not Shown
	67379	Allen Wrench
	67389	Name Plate (5561)
	67391	Warning Label
		*Order Qty. As Needed
Accessory Belts Available (3/8" x 13")		
	1861RC60	Belt Resin Cloth 60 Grit
	1861RC80	Belt Resin Cloth 80 Grit
	1861RC120	Belt Resin Cloth 120 Grit
	1861RC180	Belt Resin Cloth 180 Grit
	1861RC240	Belt Resin Cloth 240 Grit
	1861VFN	Belt Surface Conditioning Very Fine
	1861MED	Belt Surface Conditioning Medium
	1861CRS	Belt Surface Conditioning Course

Dismantling & Assembly

Disconnect tool from air supply

Press down stopper(28) to reduce tension on abrasive belt and push on idle pulley(41) to remove abrasive belt. Remove screw(33) and take off shoe(32). Tap out pulley pin(43) and this will release idle pulley assembly. Tap out 2 off bearings(42) from idle pulley(41).

Pry out pulley cap(25) and pull out apron(27). Unscrew screw(33), drive out pin(37) and remove adjust arm(38) and spring(39). Drive out stopper pin(36) and pull out tension arm(35) and spring(34). Drive out pin(30) and take off stopper(28) and spring(2).

Insert a rod in the hole in drive pulley(22) to prevent rotation and remove nut(24) and washer(23). Take off drive pulley(22). Take out adjust screw(31) to be able to remove wheel cover(26).

Unscrew inlet bushing(11) and take out deflector(10). Drive out lever pin(9) and remove throttle lever(8).

Unscrew motor nut(12) from motor housing(1) with O-ring(13). Tap carefully [so as not to damage the thread] rotor(17) to remove the motor assembly from motor housing(1). Note how drive pulley(22) locates on pin(19) in rotor(17). Pin(19) can be taken out of rotor(17). When removing the motor assembly note how pin(44) in cylinder(16) locates the motor assembly in the groove in motor housing(1) and is located at the rear plate(15) end. Hold motor assembly and again tap the threaded end of rotor(17) to drive rotor(17) through front plate(20) and bearing(21) assembly. Tap out bearing(21) from front plate(20). Take off cylinder(16) and 4 off rotor blades(18). Support the rear end plate(15) in a piece of tube just slightly larger than the maximum diameter of the rotor and tap the non threaded end of the rotor(17) to drive the rotor(17) through the rear end plate(15) and bearing(14) assembly. Tap out bearing(14) from rear end plate(15). Unscrew valve body(7) and take out O-rings(6) and (5), valve stem(4) with O-ring(3) and spring(2).

Reassembly

Clean all parts and examine for wear, particularly O-rings, bearings and rotor blades. Use only distributor or manufacturer supplied spare parts. Pack all bearings with a general purpose grease and reassemble in the reverse order. Refit belt and adjust alignment using screw(33).

Operation Specification *	
Air Consumption	8 CFM
Length	11" (280mm)
Air Inlet Thread	1/4-18 NPT
* at 90 PSIG	

Notes

Declaration of Conformity

Sioux Tools Inc.

2901 Floyd Boulevard, P.O. Box 507, Sioux City, Iowa 51102, U.S.A.

declare under our sole responsibility that the product

Model 5561 10mm Belt Sander, Serial Number

to which this declaration relates is in conformity with the following standard(s) or other normative document(s)

EN792 (Draft), EN292 Parts 1 & 2, ISO 8662 Parts 1 & 8, Pneurop PN8NTC1

following the provisions of **89/392/EEC as amended by 91/368/EEC & 93/44/EEC Directives**

R.V.Caskey (V.P./General Manager)

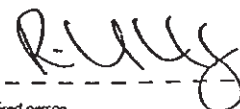

Name and signature or equivalent marking of authorised person