



# PARTS LIST FOR NO. 1 SERIES "1AM" AIRCRAFT ANGLE TOOLS (Serial "B")

Form Z302B  
Date 2008February6/E  
Page 1 of 4

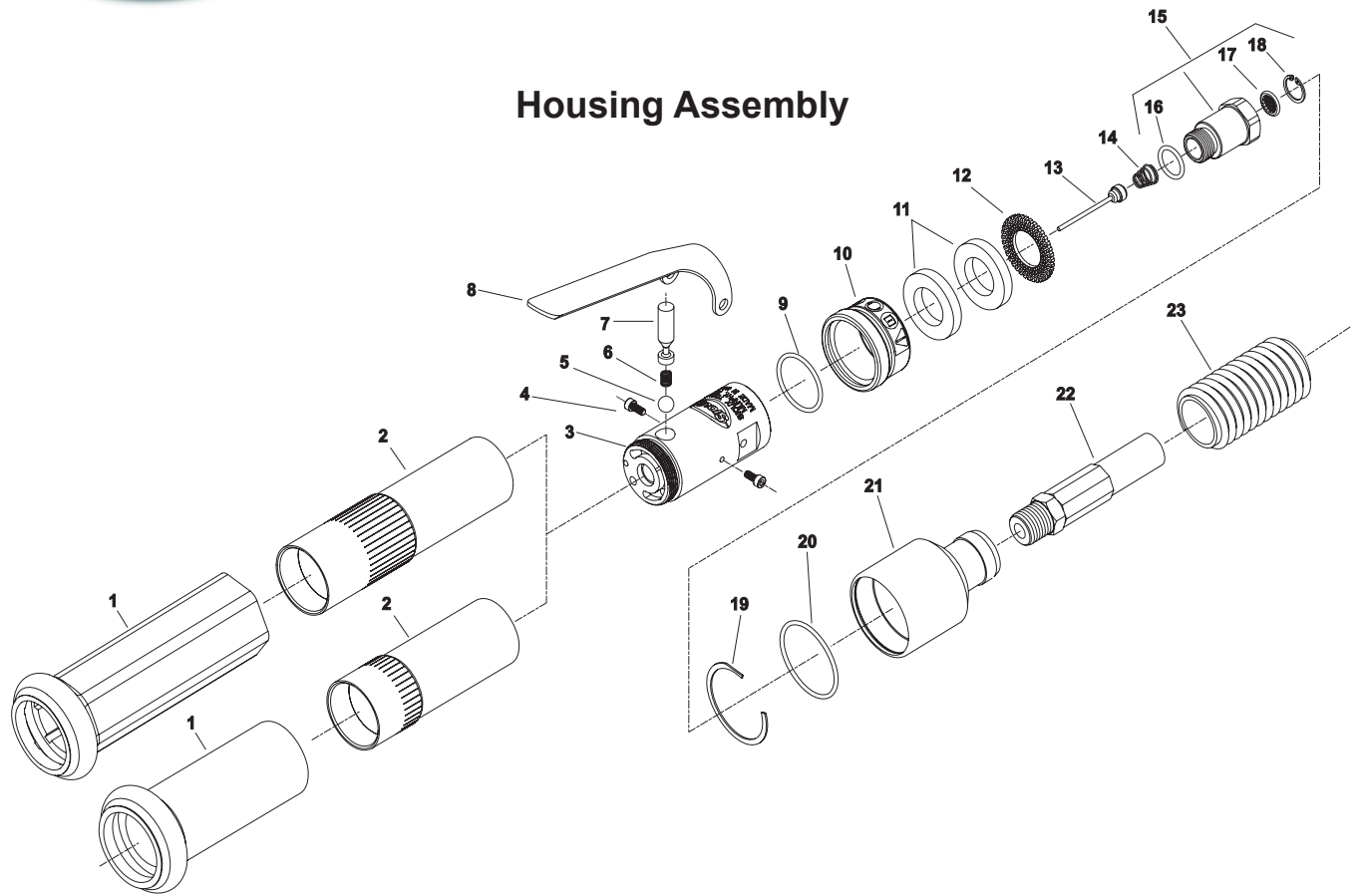

Fig. No.	Part No.	Description
1.	66193A	Housing Sleeve (Short)
	66124	Housing Sleeve (Long)
2.	66010	Housing Assembly (Non-Reversing) (2200, 2800, 4300 RPM)
	66011	Housing Assembly (Non-Reversing)(800 RPM)
3.	66008	Block Housing (Non-Reversing)
4.	06099	Screw (2)*
5.	10299	Steel Ball 1/4" Dia.
6.	21211B	Lock Plunger Spring
7.	66020	Plunger
8.	35235	Lever
9.	04210	O-Ring
10.	66018	Silencer Housing
11.	66191	Felt Washer (2)*
12.	66017	Diffuser Screen

Fig. No.	Part No.	Description
13.	66035	Valve Assembly
14.	21441	Spring
15.	66016	Inlet Adapter
16.	14312	O-Ring
17.	30463	Screen
18.	21541	Retaining Ring
19.	66034	Retaining Ring
20.	14371	Ring-"O"
21.	66033	Exhaust Adapter
22.	1359	Air Hose
23.	65723	Exhaust Hose

Remote Exhaust

\*Order Quantity As Required  
FURNISH CATALOG, SERIAL, AND MODEL NUMBER WHEN ORDERING PARTS

# SIoux TOOLS INC.

250 SNAP-ON DRIVE ■ PO BOX 1596 ■ MURPHY, NC 28906 ■ USA ■ Phone: 800-722-7290 ■ www.siouxtools.com

Printed In U.S.A.

# PARTS LIST FOR NO. 1 SERIES "1AM" AIRCRAFT ANGLE TOOLS (Serial "B")

## Single Reduction (2200, 2800, 4300 RPM)

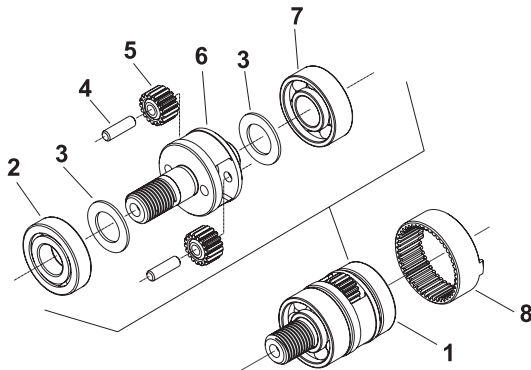

Fig. No.	Part No.	Description
1.	43803	Ass'y—Planetary (2200 RPM)
	43804	Ass'y—Planetary (2800 RPM)
	78504A	Ass'y—Planetary (4300 RPM)
2.	10257	Bearing—Ball
3.	25680	Washer (2)*
4.	30453A	Pin (2)*
5.	19212	Gear—Idler (2200RPM)
	19195	Gear—Idler (2800RPM)
	66082	Gear—Idler (4300 RPM)
6.	44920	Carrier—Gear (2200 RPM)
	44921	Carrier—Gear (2800 RPM)
	78504	Carrier—Gear (4300 RPM)
7.	10241	Bearing—Ball
8.	19189	Gear—Ring

## Double Reduction (800 RPM)

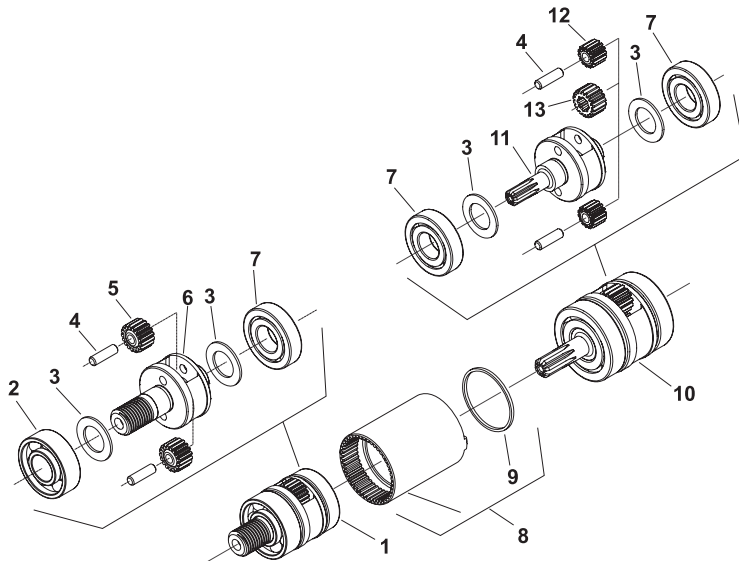

Fig. No.	Part No.	Description
1.	43804	Ass'y—Planetary (800 RPM)
2.	10257	Bearing—Ball
3.	25680	Washer (4)*
4.	30453A	Pin (4)*
5.	19195	Gear—Idler (800R PM)(2)*
6.	44921	Carrier—Gear (800 RPM)
7.	10241	Bearing—Ball (3)*
8.	19190	Gear—Ring
9.	21537	Retainer Ring
10.	66087	1st Planetary Ass'y (800 RPM)
11.	66079	Gear Carrier (800 RPM)
12.	66078	Idler Gear (800 RPM) (2)*
13.	66077	Pinion Gear (800 RPM) (2)*

## Motor Assembly

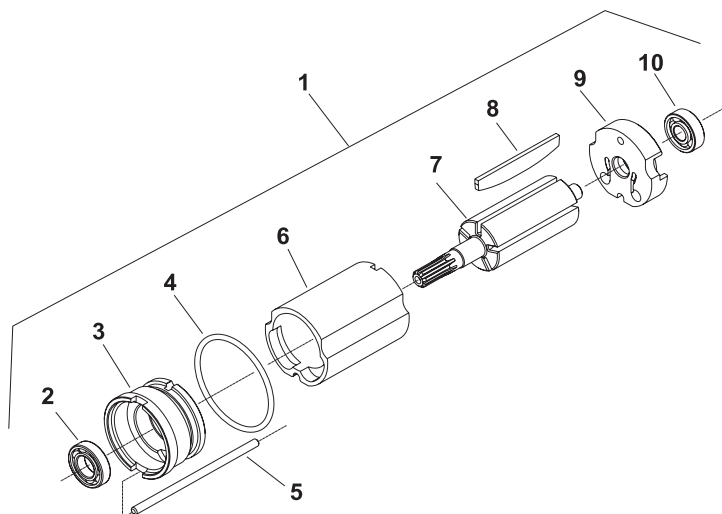

Fig. No.	Part No.	Description
1.	65999	Ass'y-Motor (6 Tooth)(2200 RPM)
	66000	Ass'y-Motor (8 Tooth)(800, 2800 RPM)
	66085	Ass'y-Motor (10 Tooth)(4300 RPM)
2.	65998	Bearing-Ball
3.	65995	End Plate-Lower
4.	14391	Ring-"O"
5.	66132	Pin
6.	65994	Cylinder (800, 2200, 2800 RPM)
	66005	Cylinder (4300 RPM)
7.	65991	Rotor (6 Tooth)(2200 RPM)
	65992	Rotor (8 Tooth)(800, 2800 RPM)
	66084	Rotor (10 Tooth)(4300 RPM)
8.	14762	Vane (Set of 5)
9.	65997	End Plate-Upper (800, 2200, 2800 RPM)
	66004	End Plate-Upper (4300 RPM)
10.	10255	Bearing-Ball

\*Order Quantity As Required

**FURNISH CATALOG, SERIAL, AND MODEL NUMBER WHEN ORDERING PARTS**

# PARTS LIST FOR NO. 1 SERIES "1AM" AIRCRAFT ANGLE TOOLS (Serial "B")

## 45 Degree Angle Head Assembly

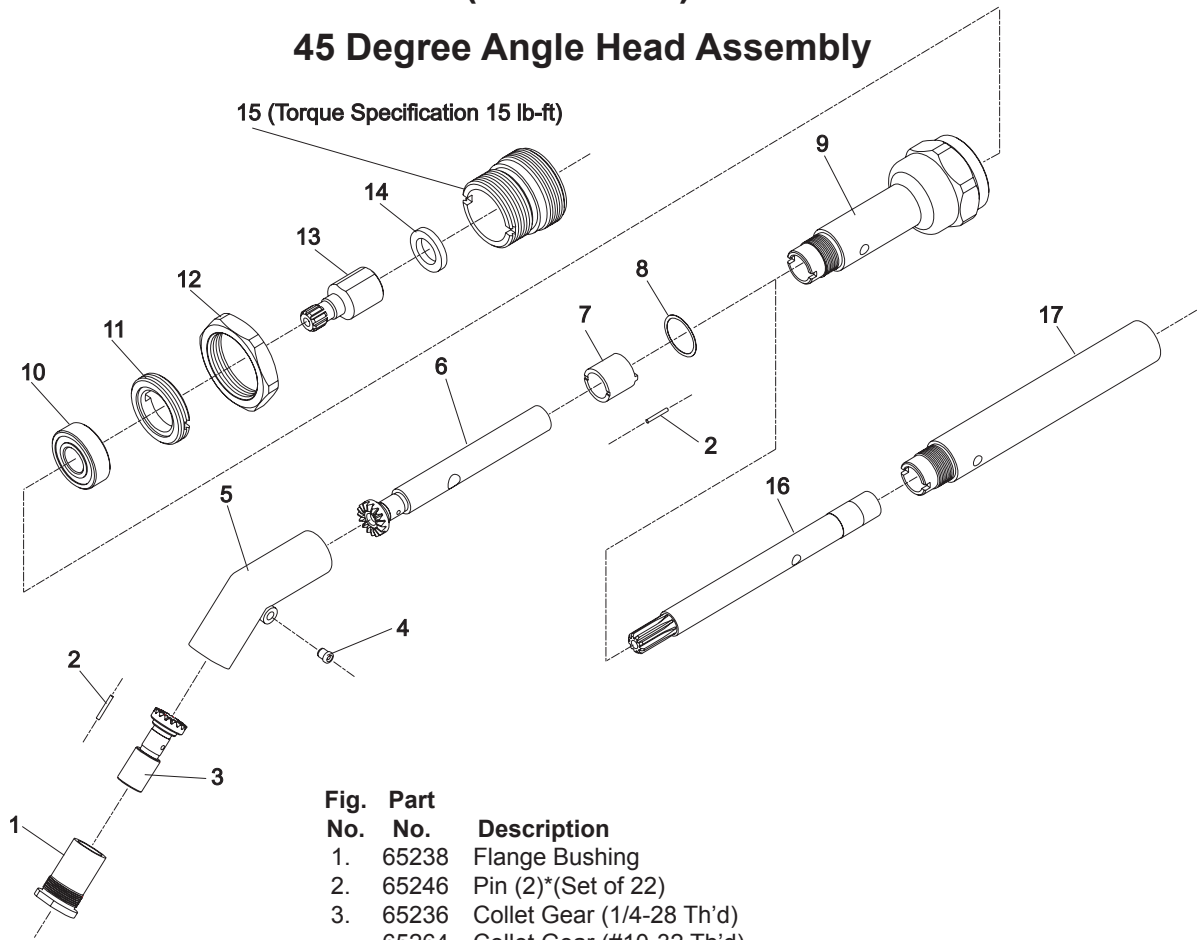

Fig. No.	Part No.	Description
1.	65238	Flange Bushing
2.	65246	Pin (2)*(Set of 22)
3.	65236	Collet Gear (1/4"-28 Th'd)
	65264	Collet Gear (#10-32 Th'd)
	65538	Collet Gear (9/32"-40 Th'd)
4.	30375	Grease Fitting
5.	65237	45 Degree Housing (Includes Fig. 4)
6.	65235	Pinion
7.	65245	Bearing Retainer
8.	65242	.005"Shim (Order Quantity As Needed)
9.	65244	Angle Drill Housing
10.	10257	Ball Bearing
11.	65243	Retaining Nut
12.	65143	Jam Nut
13.	65146	Spindle Adapter
14.	44122	Spacer
15.	65231	Adapter
16.	65486	Drive Shaft Extension
17.	65487	Housing Extension
	65213	Complete Assembly (1/4"-28 Th'd) (Includes Figs. 1 thru 11)
	65265	Complete Assembly (#10-32 Th'd) (Includes Figs. 1 thru 11)
	65541	Complete Assembly (9/32"-40 Th'd) (Includes Figs. 1 thru 11)

\*Order Quantity As Required  
**FURNISH CATALOG, SERIAL, AND MOD-  
EL NUMBER WHEN ORDERING PARTS**



# PARTS LIST FOR NO. 1 SERIES "1AM" AIRCRAFT ANGLE TOOLS (Serial "B")

## 90 Degree Angle Head Assembly

\*Order Quantity As Required  
FURNISH CATALOG, SERIAL, AND MODEL NUMBER WHEN ORDERING PARTS

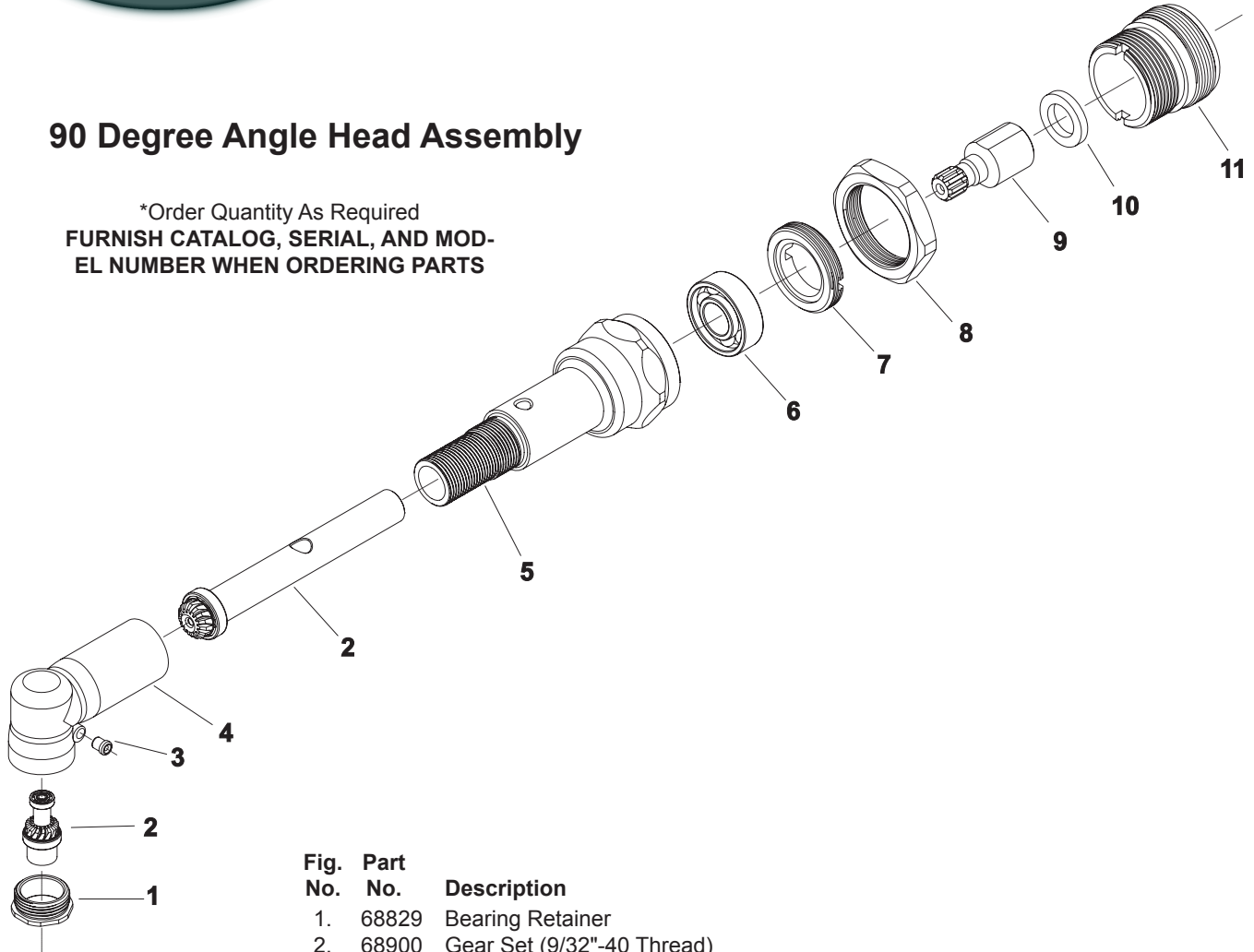

Fig. No.	Part No.	Description
	1.	68829 Bearing Retainer
	2.	68900 Gear Set (9/32"-40 Thread) 68901 Gear Set (1/4"-28 Thread)
	3.	30375 Grease Fitting
	4.	68840 90° Housing (Includes Fig 3)
	5.	68834 Angle Drill Housing
	6.	10257 Ball Bearing
	7.	65243 Retaining Nut
	8.	65143 Jam Nut
	9.	65146 Spindle Adapter
	10.	44122 Spacer
	11.	65231 Adapter
	68836	Complete Assembly (9/32"-40 Thread)(Includes Figures 1-7)
	68837	Complete Assembly (1/4"-28 Thread)(Includes Figures 1-7)

# SIoux TOOLS INC.