



INSTRUCTIONS FOR ARMATURE REMOVAL FROM GEAR CASE 1200DI, 1203DI, 1216DI, 1267DI AND 1274A THRU 1279A

The armature assembly is secured in the gear case by a shrink fit on the front armature bearing.

In order to remove the armature from the gear case, it is necessary to heat the gear case to approximately 200° F in the bearing bore area.

Ideally, the gear case should be heated with a heat gun, such as the SIOUX Cat. No. 1400, directing the heat to the bearing bore area for a few minutes, then tapping the gear case with a soft blow hammer while holding the armature. On units with the metal fan, the direction of heat can be from the armature side of the gear case. On units with the plastic fan, the threaded spindle and large gear must be removed along with the grease. The direction of heat must then be from the gear case cavity, so as to prevent damage to the plastic fan.

ALLOW TIME FOR THE PARTS TO COOL BEFORE PROCEEDING.

Before installing the new armature, the aluminum plate, #35834, must be installed on the gear case.

Place the plate, #35834, on the back of the gear case, aligning the 2 counter-sunk holes with the existing holes on the back of the gear case. Install the 2 Pan Head Thread Forming screws, #07249, to secure the plate to the gear case.

To install the new armature in the gear case, heat the gear case to approximately 200° F and insert the armature, complete with bearing and pinion, into the bearing bore of the gear case. Allow unit to cool with the armature up in a vertical position to avoid cocking of the bearing.

WARNING

- 1) TO AVOID INJURY, USE HEAVY INSULATED GLOVES WHEN HANDLING HOT PARTS.
- 2) DO NOT USE OPEN FLAME TO HEAT ASSEMBLY.
- 3) DO NOT USE HEAT GUN IN PRESENCE OF FLAMMABLE MATERIALS.

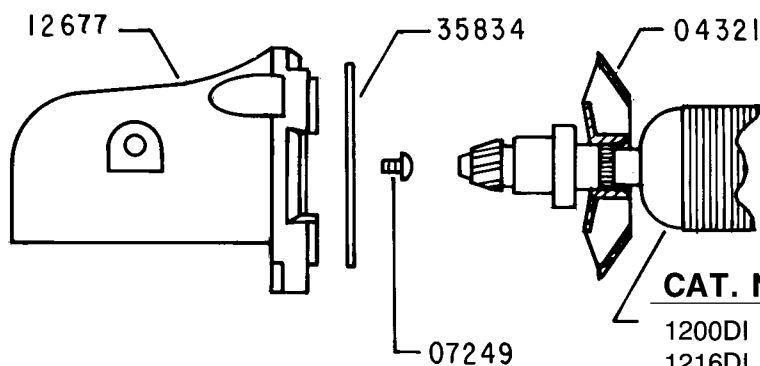

CAT. NO.	MFG. NO.
1200DI & 1203DI	28935
1216DI	28936
1267DI	28937
1274A THRU 1279A	28992

**SIoux
TOOLS INC.**

2901 FLOYD BOULEVARD ■ SIOUX CITY, IOWA 51102 ■