



SIoux
TOOLS INC.

2901 FLOYD BOULEVARD ■ SIOUX CITY, IOWA 51102 ■

Form A-42—8/80
E.D.—8/80

INSTRUCTIONS

No. 2325 (7") & No. 2328 (9") Grinder Guard

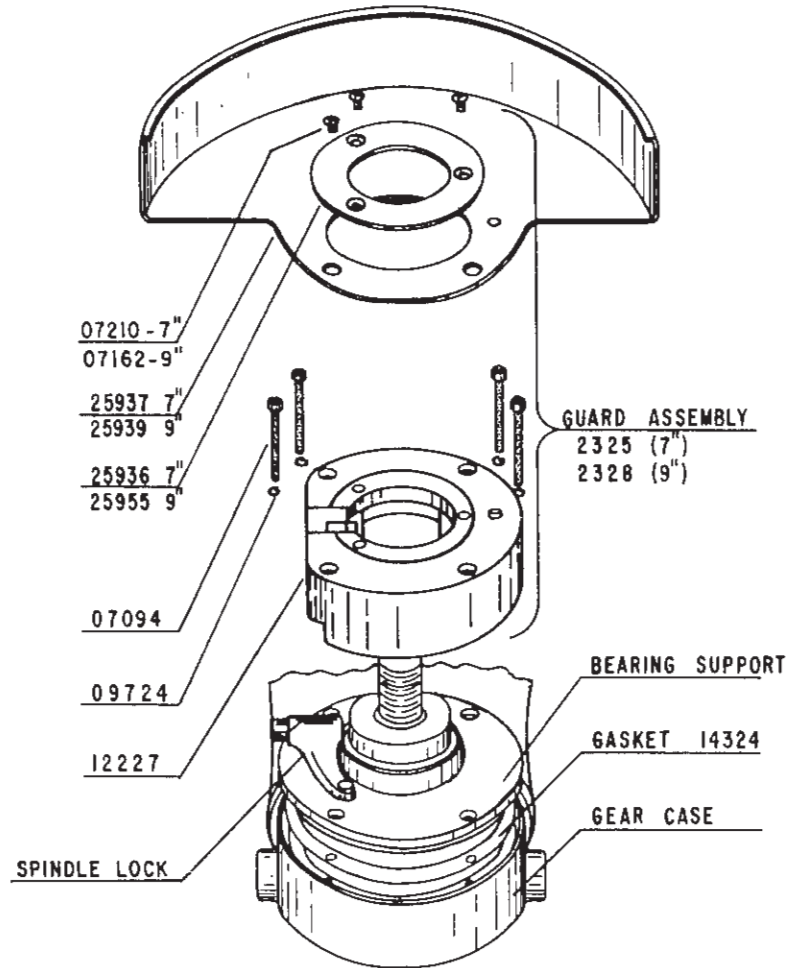

Disassembly of this guard kit is unnecessary for proper installation by the following procedure.

Remove four fillister head screws and four fiber washers from bearing support. These will be replaced by screws and washers included in guard kit.

Remove bearing support and spindle assembly. If bearing support does not remove easily, hold spindle and gently tap gear case.

Carefully place gasket No. 14324 in gear case aligning four holes properly. Replace bearing support and spindle assembly positioning spindle lock as shown.

Place guard assembly on bearing support aligning four holes in guard with those in bearing support. Insert four screws and lock washers, furnished in kit, and complete assembly by tightening to gear case.