



**SIoux  
TOOLS INC.**

2901 FLOYD BOULEVARD ■ SIOUX CITY IOWA 51102 ■

Form A313B  
Dated 7/80

## Parts List for No. 1646M 1/4", No. 1649M 1/2" and No. 1653M 3/4" Filters

**NOTICE:** A SPECIAL PROCEDURE IS REQUIRED TO REMOVE THE MECHANICAL DRAINER ASSEMBLY, FIGURE 11, FROM THE BOWL, FIGURE 6. INSERT A 7/64" WRENCH IN THE HOLE IN THE BOTTOM OF THE ADAPTOR NUT, FIGURE 8. HOLD THIS WRENCH IN POSITION WHILE TURNING THE ADAPTOR NUT COUNTER-CLOCKWISE. DO NOT HOLD THE FLOAT WHILE UNSCREWING THE NUT. IF THIS PROCEDURE IS NOT FOLLOWED, THE DRAINER ASSEMBLY WILL BE SEVERELY DAMAGED.

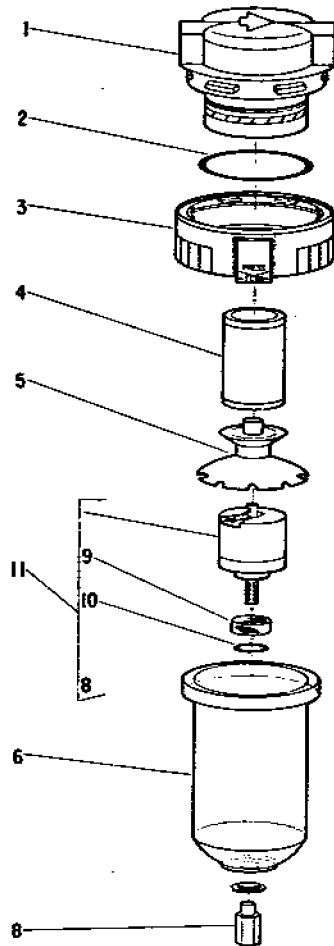

Fig- ure	Part No.	Name	Fig- ure	Part No.	Name
1	00191	Body (1646M)	5	00197	Baffle (1646M, 1649M)
	00194	Body (1649M)		00213	Baffle (1653M)
	00211	Body (1653M)	6	00219	Bowl—Metal (1646M, 1649M)
2	00183	Ring—"O" (1646M, 1649M)		00220	Bowl—Metal (1653M)
	00205	Ring—"O" (1653M)	8	00200	Nut—Adaptor
3	00181	Ring—Clamp (1646M, 1649M)	9	00201	Screen
	00203	Ring—Clamp (1653M)	10	14274	Ring—"O"
4	00196	Filter (1646M, 1649M) (Incl's. Fig. 2)	11	00202	Assy.—Mechanical Drainer
	00212	Filter (1653M) (Incl's. Fig. 2)			

**Furnish Catalog and Serial Number When Ordering Parts**