



PARTS LIST FOR NO. 3 SERIES ANGLE NUTRUNNERS (TORQUE CONTROL)

Form A289B
Date 2004October8/A
Page 1 of 4

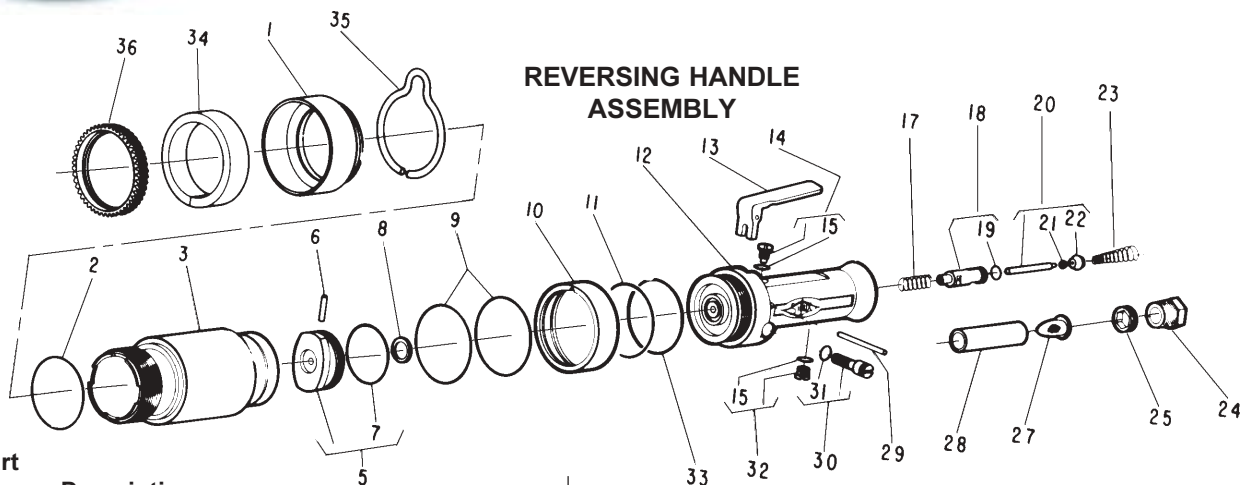

Fig. No.	Part No.	Description
1.	54156	Deflector
2.	04206	Ring—"O"
3.	§	Housing—Motor
5.	53075	Ass'y—Valve Plate (Up To Serial "B")
	53746	Ass'y—Valve Plate (Includes Fig. 8)(Serial "B" & Up To Serial "D")
	63009	Ass'y—Valve Plate (Serial "D" & Up)
6.	66122	Pin
7.	04222	Ring—"O"
8.	14390	Ring—Quad (Up To Serial "B")
	14309	Ring—"O" (Serial "B" & Up)
9.	04223	Ring—"O" (2)*
10.	44915	Ring—Reversing
11.	21758	Ring—Lock
12.	§	Handle
13.	11560	Lever
14.	43774	Ass'y—Screw & "O" Ring
15.	14369	Ring—"O" (2)*
17.	41253	Spring—Reset
18.	43775	Ass'y—Valve Seat & "O" Ring
19.	14394	Ring—"O"
20.	43776	Ass'y—Valve
21.	25957	Washer

Fig. No.	Part No.	Description
22.	04205	Valve
23.	41245	Spring—Throttle
24.	44100	Bushing—Reducing 3/8" to 1/4"
25.	44997	Retainer
27.	33993	Ass'y—Air Screen
28.	44787	Tube
29.	30606	Pin—Dowel
30.	43777	Ass'y—Air Regulator Screw & "O" Ring
31.	14291	Ring—"O"
32.	44253	Ass'y—Oiler Screw & "O" Ring
33.	04224	Ring—"O"
34.	14100	Liner—Deflector
35.	41238	Bail
36.	54182	Diffuser—Air

§ Fig 3 & 12 available only as an Ass'y No. 12347 which also includes Fig 19 & 31 & New Style Fig 5, or 53133 which includes Fig 3-33.

REVERSING MOTOR ASSEMBLY

Fig. No.	Part No.	Description
1.	35227	Washer
2.	10221	Bearing—Ball
3.	13226	Plate—Front End (Includes Figure 2)
4.	44871	Rotor (300 RPM)
	44872	Rotor (480, 700, 1000 RPM)
5.	43888	Ass'y—Rotor Vane (Set of 5)
6.	54049	Cylinder—Reversing
7.	13246	Plate—Rear End
8.	10241	Bearing—Ball
9.	21534	Ring—Retaining

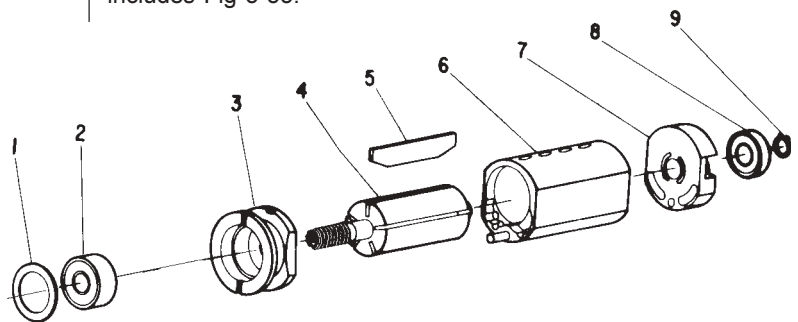

Fig. No.	Part No.	Description
10.	44794	Rod—Thru Motor Push
	53058	Ass'y—Complete Motor (300 RPM)
	53059	Ass'y—Complete Motor (480, 700, 1000 RPM)

*Order Quantity As Required

**SIoux
TOOLS INC.**

FURNISH CATALOG, SERIAL, AND MODEL NUMBER
WHEN ORDERING PARTS

250 SNAP-ON DRIVE ■ PO BOX 1596 ■ MURPHY, NC 28906 ■ USA ■

Printed In U.S.A.

DOUBLE REDUCTION GEAR CASE

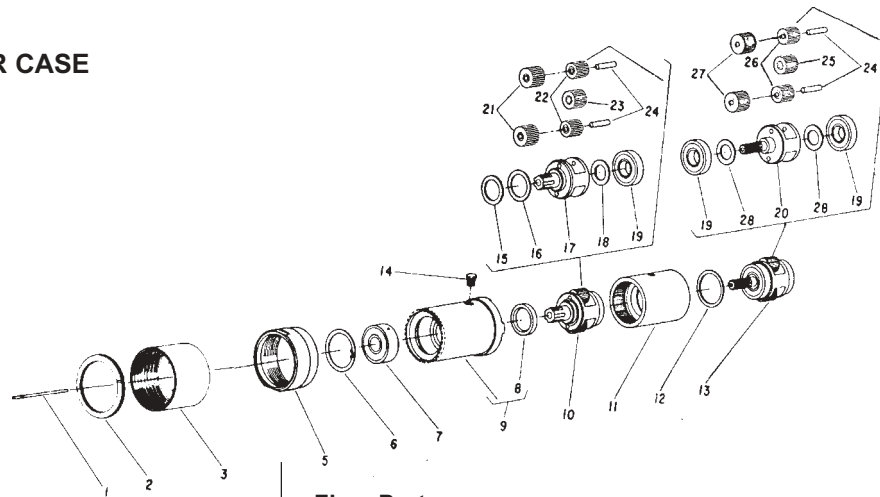

Fig. No.	Part No.	Description
1.	44793	Rod—Thru Gear Case Push
2.	21763	Ring—Retaining
3.	54122	Sleeve—Lock
5.	44798	Sleeve—Lock
6.	21773	Ring—Retaining
7.	10251	Bearing—Ball
8.	30258	Seal—Oil
9.	54120	Case—Gear
10.	43582	Ass'y—2nd Planetary Gear (Reversing) (300, 480 RPM)
	43583	Ass'y—2nd Planetary Gear (Reversing) (700 RPM)
	43581	Ass'y—2nd Planetary Gear (Reversing) (1000 RPM)
11.	19207	Gear—Ring
12.	21531	Ring—Lock
13.	43586	Ass'y—1st Planetary Gear (Reversing) (300 RPM)
	43655	Ass'y—1st Planetary Gear (Reversing) (480 RPM)
	43587	Ass'y—1st Planetary Gear (Reversing) (700 RPM)
	43585	Ass'y—1st Planetary Gear (Reversing) (1000 RPM)
14.	44797	Screw—Lock
15.	21524	Ring—Retainer (700 RPM)

Fig. No.	Part No.	Description
	21753	Ring—Retainer (1000 RPM)
16.	35260	Washer (1000 RPM)
17.	44803	Carrier—2nd Planetary (300, 480 RPM)
	44802	Carrier—2nd Planetary (700 RPM)
	44801	Carrier—2nd Planetary (1000 RPM)
18.	25976	Washer
19.	10203	Bearing—Ball (3)*
20.	44807	Carrier—Pinion Planetary (300 RPM)
	44868	Carrier—Pinion Planetary (480 RPM)
	44806	Carrier—Pinion Planetary (700 RPM)
	44805	Carrier—Pinion Planetary (1000 RPM)
21.	19324	Ass'y—Gear & Bearing (300, 480 RPM)(2)*
22.	19326	Ass'y—Gear & Bearing (700 RPM)(2)*
	19325	Ass'y—Gear & Bearing (1000 RPM)(2)*
23.	19205	Gear—Pinion (700 RPM)
	19206	Gear—Pinion (1000 RPM)
24.	30467	Pin (300, 480, 700 RPM)(4)*
	30369	Pin (1000 RPM)(4)*
25.	19205	Gear—Pinion (480, 700 RPM)
	19206	Gear—Pinion (1000 RPM)
26.	19326	Ass'y—Gear & Bearing (480, 700 RPM)(2)*
	19325	Ass'y—Gear & Bearing (1000 RPM)(2)*
27.	19324	Ass'y—Gear & Bearing (300 RPM)(2)*
28.	35135	Washer (2)*

TORQUE CONTROL CLUTCH

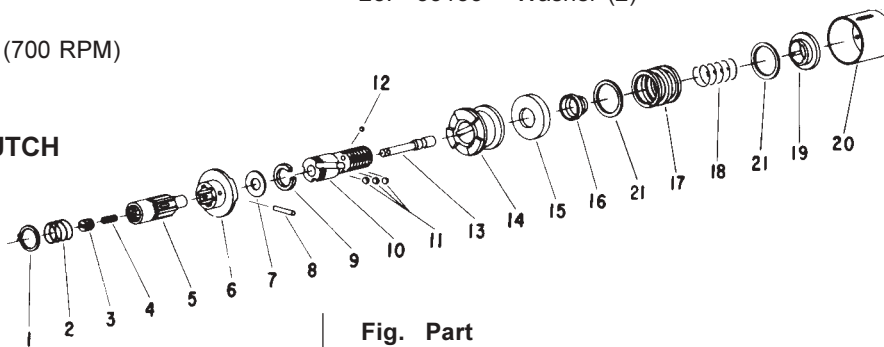

Fig. No.	Part No.	Description
1.	21490	Ring—Retaining
2.	41231	Spring
3.	44967	Plug
4.	41230	Spring—Clutch Reset
5.	44968	Driver—Splined
6.	44969	Clutch—Drive
7.	35254	Washer
8.	30219	Pin
9.	21752	Ring—Retaining
10.	44970	Spindle—Clutch Drive
11.	10291	Ball (9)*

Fig. No.	Part No.	Description
12.	10902	Ball (3)*
13.	44963	Slide—Automatic Shutoff
14.	44965	Jaw—Clutch
15.	54123	Washer
16.	44966	Ring—Lockout
17.	41243	Spring—Compression
18.	41232	Spring
19.	54126	Washer—Index
20.	44964	Nut—Adjusting
21.	25600	Ring—Retaining (2)*

*Order Quantity As Required

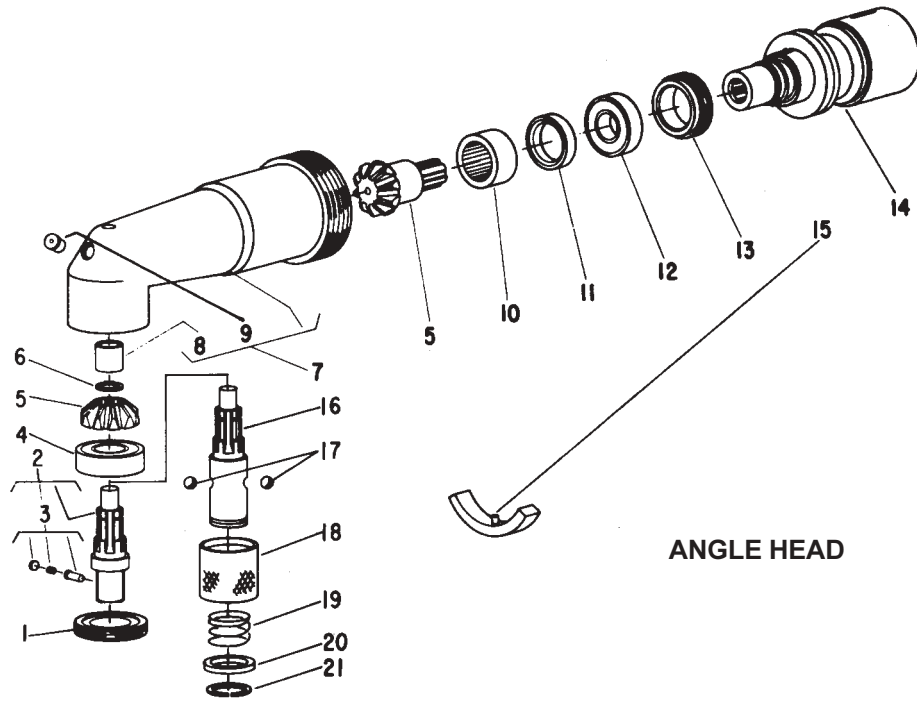

Fig. Part

No.	No.	Description
1.	44813	Retainer—Bearing
2.	43596	Ass'y—Tool Spindle
3.	43890	Ass'y—Socket Retainer
4.	10265	Bearing
5.	19722	Gear—Matched Set, Spiral Bevel Gear & Pinion
6.	21781	Ring—Retaining
7.	53102	Ass'y—Angle Head
8.	10012	Bearing
9.	30356	Fitting—Grease
10.	10081	Bearing
11.	34808	Spacer—Bearing
12.	10239	Bearing
13.	44775	Retainer—Bearing
14.	53131	Ass'y—Clutch Torque Control
15.	53126	Wrench—Adjusting
16.	22668	Spindle—7/16" Hex
17.	10291	Ball—Steel
18.	54008	Retainer—Ball
19.	41241	Spring
20.	54009	Ring—Guide
21.	21754	Ring—Retaining

**FURNISH CATALOG, SERIAL, AND MODEL NUMBER
WHEN ORDERING PARTS**



**SIoux
TOOLS INC.**

250 SNAP-ON DRIVE ■ PO BOX 1596 ■ MURPHY, NC 28906 ■ USA ■

Printed In U.S.A.