



No. 656 Rocker Arm Attachment Assembly and Operating Instructions

Form A286B
Date 2004October7/A
Page 1 of 1

GRINDING ROCKER ARMS

Dress wheel with built-in dressing tool on right side of machine before mounting the SIoux Rocker Arm.

Assembly and Operation

The grinding wheel should be properly dressed before mounting the Rocker Arm Attachment.

Place the pivot post, with its swivel block base and the radius arm base, in the 3/8" diameter hole in the top of the right wheel guard, the flat on the post facing forward. Seat the post firmly and secure with the oval point set screw.

Place arbor holder on radius arm, cone arbor in the arbor holder and alignment gauge on arbor. Place radius arm in the radius arm base. **Do not tighten the two cone point set screws.** Adjust height of alignment gauge to the horizontal center of the grinding wheel and position the arbor holder to allow the recessed pad of the alignment gauge to make full contact with the face of the grinding wheel. Hold recessed pad of alignment gauge against face of grinding wheel while tightening three thumb screws. Hold alignment gauge firmly against wheel face and tighten the two cone point set screws locking the radius arm.

Remove alignment gauge.

Install the cone on arbor, small end down. Place rocker arm on arbor and adjust upper cone position to bring rocker arm pad to horizontal center of wheel. Place lower cone on arbor to firmly hold rocker arm. Position arbor holder to grind full pad area.

Wet grind rocker arms by lightly pressing arm pad against grinding wheel. Swivel attachment left and right until desired surface is attained. The radius arm can be swung upward to facilitate loading and unloading. Proper adjustment of the tension screw will allow the operator to move the radius arm up or down—but not drop accidentally.

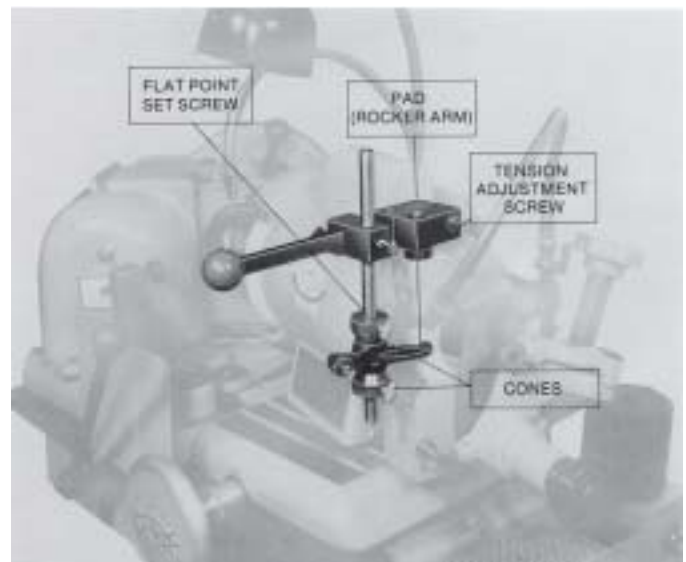
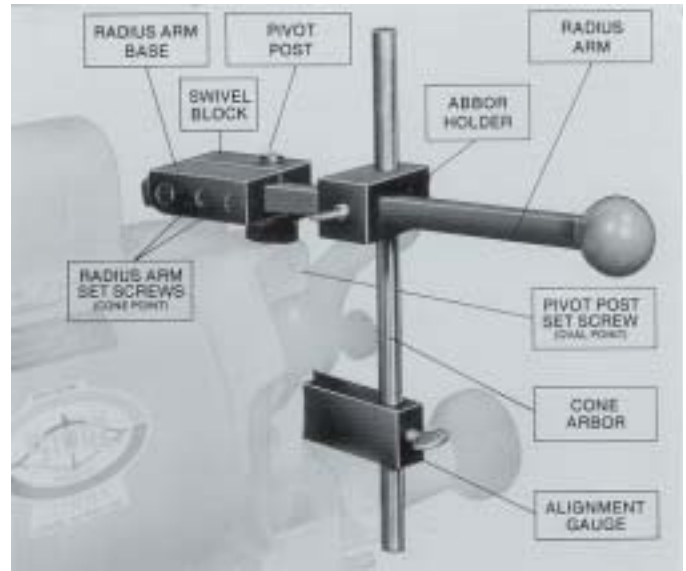

⚠ WARNING



Some dust created by power sanding, sawing, grinding, drilling, and other construction activities contains chemicals known to cause cancer, birth defects or other reproductive harm.

⚠ ADVERTENCIA



El polvo generado al lijar, aserrar, afilar, taladrar y realizar otras tareas de construcción contiene sustancias químicas que podrían causar cáncer, malformaciones congénitas y otras alteraciones del aparato reproductor.

SIoux TOOLS INC.

250 SNAP-ON DRIVE ■ PO BOX 1596 ■ MURPHY, NC 28906 ■ USA ■

Printed In U.S.A.