

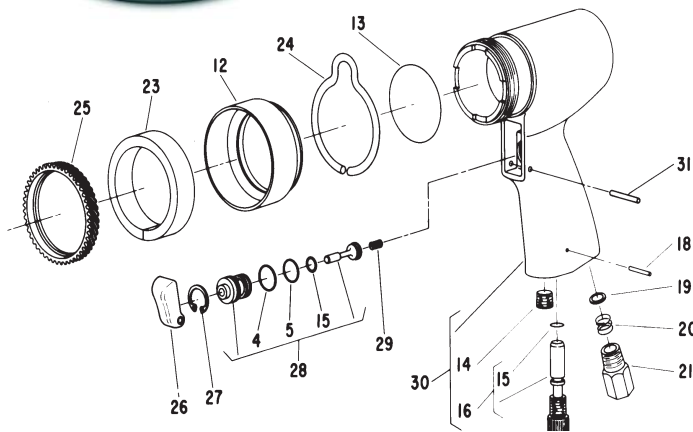

# PARTS LIST FOR NO. 3 SERIES PISTOL AND "T" HANDLE SCREWDRIVERS

Form A278F  
Date 10-00/B  
Page 1 of 6



**NON-REVERSING HANDLE ASSEMBLY**  
(SERIAL NO'S. STARTING WITH "B" & "D")

Fig. No.	Part No.	Description
4.	14309	Ring—"O"
5.	14312	Ring—"O"
12.	54156	Deflector
13.	04206	Ring—"O"
14.	30246	Plug—Oil
15.	14291	Ring—"O" (2)*
16.	53029	Ass'y—Regulator & "O" Ring
18.	30625	Pin—Groove
19.	30463	Screen
20.	41220	Spring
21.	30249	Connection—Air Hose
23.	14100	Liner—Deflector
24.	41238	Bail
25.	54182	Diffuser—Air
26.	12308	Trigger
27.	21775	Ring—Retaining
28.	53327	Ass'y—Valve
29.	21211	Spring
30.	53328	Housing (Includes Figs. 14-21, 26-29, 31)
	53336	Housing (Includes Figs. 14-16, 18)
31.	30322	Pin

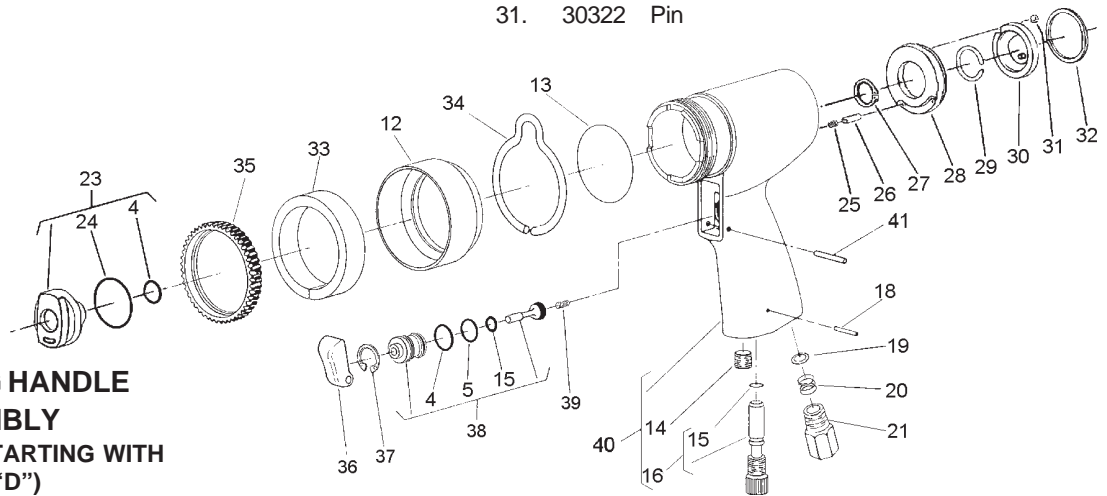

**REVERSING HANDLE ASSEMBLY**  
(SERIAL NO'S. STARTING WITH "C" & "D")

Fig. No.	Part No.	Description
4.	14309	Ring—"O" (2)*
5.	14312	Ring—"O"
12.	54156	Deflector
13.	04206	Ring—"O"
14.	30246	Plug—Oil
15.	14291	Ring—"O" (3)*
16.	53029	Ass'y—Regulator & "O" Ring
18.	30625	Pin—Groove
19.	30463	Screen
20.	41220	Spring
21.	30249	Connection—Air Hose
23.	53051	Plate—Valve
24.	04222	Ring—"O"
25.	21223	Spring—Friction
26.	30062	Pin
27.	21482	Ring—Retaining

Fig. No.	Part No.	Description	*Order Quantity As Required
28.	54462	Body—Actuator	
29.	21757	Ring—Retaining	
30.	54461	Insert	
31.	10306	Ball—Steel	
32.	21785	Ring—Retaining	
33.	14100	Liner—Deflector	
34.	41238	Bail	
35.	54182	Diffuser—Air	
36.	12308	Trigger	
37.	21775	Ring—Retaining	
38.	53327	Ass'y—Valve	
39.	21211	Spring	
40.	53329	Housing (Includes Fig 14-32, 36-39, 41)	
	53337	Housing (Includes Fig 14-16, 18, 23, 25-32)	
41.	30322	Pin	

**SIoux  
TOOLS INC.**

250 SNAP-ON DRIVE ■ PO BOX 1596 ■ MURPHY, NC 28906 ■ USA ■

FURNISH CATALOG, SERIAL, AND MODEL NUMBER WHEN ORDERING PARTS

Printed In U.S.A.

# PARTS LIST FOR NO. 3 SERIES PISTOL AND "T" HANDLE DRILLS

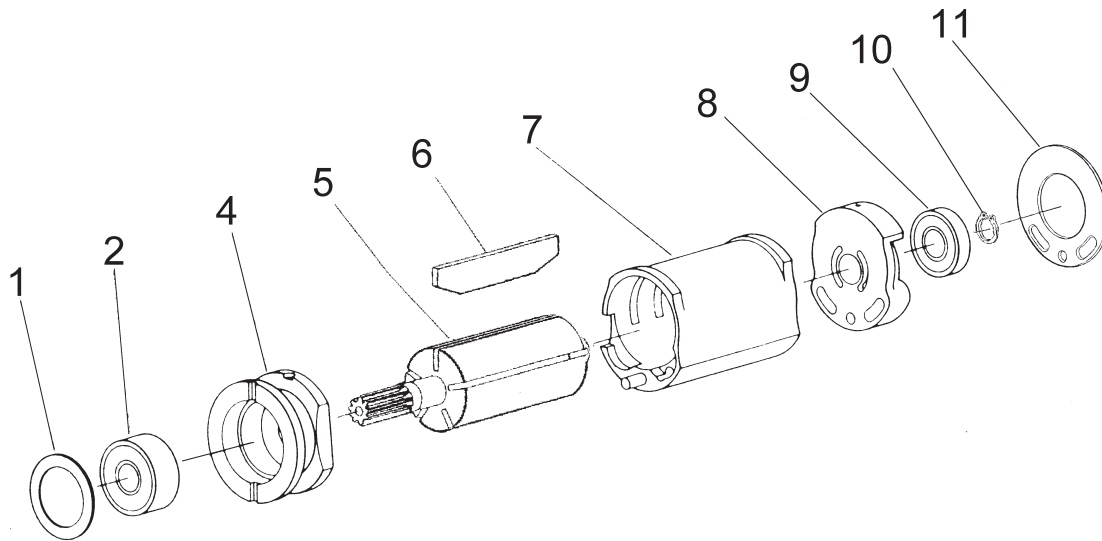

## NON-REVERSING MOTOR ASSEMBLY

Fig. No.	Part No.	Description
1.	35227	Washer
2.	10221	Bearing—Ball
4.	13226	Plate—Front End (Includes Fig. 2)
5.	44870	Rotor (2150 RPM)
	54675	Rotor ( 360, 2650 RPM)
	54676	Rotor (650, 1000, 1400 RPM)
6.	43888	Ass'y—Rotor Vane (Set of 5)
7.	44869	Cylinder
8.	13227	Plate—Rear End

Fig. No.	Part No.	Description
9.	10241	Bearing—Ball
10.	21534	Ring—Retainer
11.	14794	Gasket
	43781	Ass'y—Complete Motor (650, 1000, 1400 RPM)
	43782	Ass'y—Complete Motor (2150 RPM)
	43783	Ass'y—Complete Motor (360, 2650 RPM)

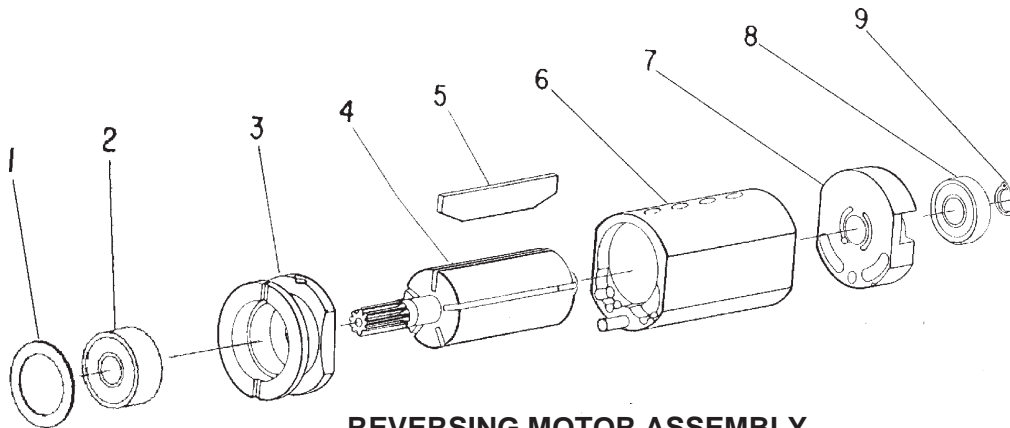

## REVERSING MOTOR ASSEMBLY

Fig. No.	Part No.	Description
1.	35227	Washer
2.	10221	Bearing—Ball
3.	13226	Plate—Front End (Includes Fig. 2)
4.	44870	Rotor (1800 RPM)
	54675	Rotor (300, 2250 RPM)
	54676	Rotor (550, 850, 1200 RPM)
5.	43888	Ass'y—Rotor Vane (Set of 5)
6.	54049	Cylinder

Fig. No.	Part No.	Description
7.	13246	Plate—Rear End
8.	10241	Bearing—Ball
9.	21534	Ring—Retainer
	53907	Ass'y—Complete Motor (550, 850, 1200 RPM)
	53057	Ass'y—Complete Motor (1800 RPM)
	53908	Ass'y—Complete Motor (300, 2250 RPM)

# PARTS LIST FOR NO. 3 SERIES PISTOL AND "T" HANDLE SCREW DRIVERS

## SINGLE REDUCTION GEAR CASE

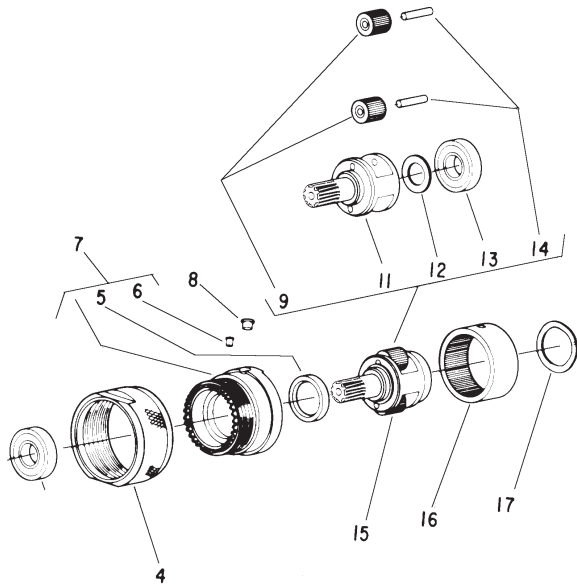

Fig. No.	Part No.	Description
1.	10251	Bearing—Ball
2.	44798	Sleeve—Lock
3.	44799	Case—Gear
4.	30258	Seal—Oil
5.	43584	Ass'y—Second Planetary Gear (1800, 2150 RPM)
	43582	Ass'y—Second Planetary Gear (2250, 2650 RPM)
6.	19208	Gear—Ring
7.	30375	Fitting—Grease
8.	44795	Pin
9.	19327	Ass'y—Gear & Bearing (1800, 2150 RPM)(2)*
	19324	Ass'y—Gear & Bearing (2250, 2650 RPM)(2)*
11.	44804	Carrier—Second Planetary (1800, 2150 RPM)
	44803	Carrier—Second Planetary (2250, 2650 RPM)
12.	25976	Washer
13.	10203	Bearing—Ball
14.	30467	Pin (2)*
15.	41236	Washer

\*Order Quantity As Needed

## DOUBLE REDUCTION GEAR CASE

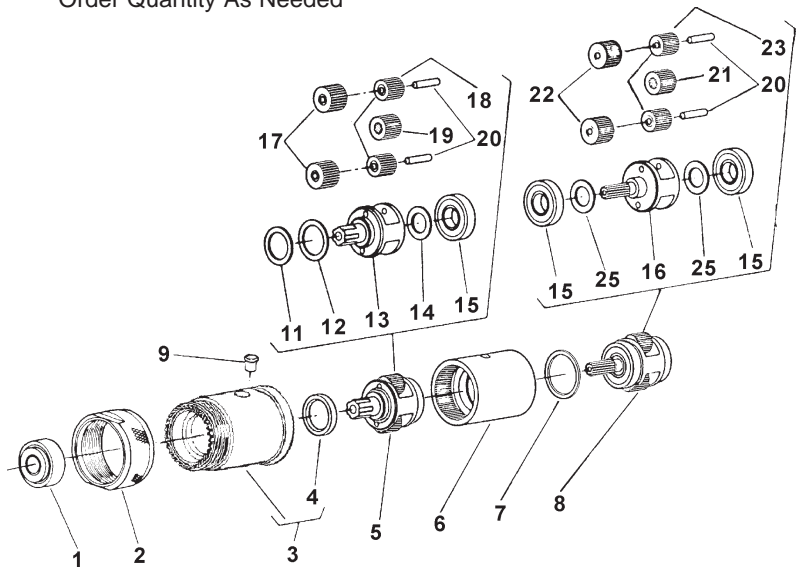

Fig. No.	Part No.	Description
1.	10251	Bearing—Ball
2.	44798	Sleeve—Lock
3.	44800	Case—Gear
4.	30258	Seal—Oil
5.	43582	Ass'y—2nd Planetary Gear (300, 360, 550, 650 RPM)
	43583	Ass'y—2nd Planetary Gear (850, 1000 RPM)
	43581	Ass'y—2nd Planetary Gear (1200, 1400 RPM)
6.	19207	Gear—Ring
7.	21531	Ring—Lock
8.	43586	Ass'y—1st Planetary Gear (300, 360 RPM)
	43655	Ass'y—1st Planetary Gear (550, 650 RPM)
	43587	Ass'y—1st Planetary Gear (850, 1000 RPM)
	43585	Ass'y—1st Planetary Gear (1200, 1400 RPM)
9.	44797	Lock—Screw
11.	21524	Ring—Retainer (850, 1000 RPM)
	21753	Ring—Retainer (1200, 1400 RPM)
12.	35260	Washer (1200, 1400 RPM)
13.	44803	Carrier—Second Planetary (300, 360, 550, 650, RPM)
	44802	Carrier—Second Planetary (650, 1000 RPM)
	44801	Carrier—Second Planetary (1200, 1400 RPM)
14.	25976	Washer
15.	10203	Bearing—Ball (3)*
16.	44807	Carrier—Pinion Planetary (300, 360 RPM)
	44868	Carrier—Pinion Planetary (550, 650 RPM)

Fig. No.	Part No.	Description
	44806	Carrier—Pinion Planetary (850, 1000 RPM)
	44805	Carrier—Pinion Planetary (1200, 1400 RPM)
17.	19324	Ass'y—Gear & Bearing (300, 360, 550, 650 RPM)(2)*
18.	19326	Ass'y—Gear & Bearing (850, 1000 RPM)(2)*
	19325	Ass'y—Gear & Bearing (1200, 1400 RPM)(2)*
19.	19205	Gear—Pinion (850, 1000 RPM)
	19206	Gear—Pinion (1200, 1400 RPM)
20.	30467	Pin (300, 360, 550, 650, 850, 1000 RPM)(4)*
	30369	Pin (1200, 1400 RPM)(4)*
21.	19205	Gear—Pinion (550, 650, 850, 1000 RPM)
	19206	Gear—Pinion (1200, 1400 RPM)
22.	19324	Ass'y—Gear & Bearing (300, 360 RPM)(2)*
23.	19326	Ass'y—Gear & Bearing (550, 650, 850, 1000 RPM)(2)*
	19325	Ass'y—Gear & Bearing (1200, 1400 RPM)(2)*
25.	35135	Washer (2)*

\*Order Quantity As Needed

# PARTS LIST FOR NO. 3 SERIES PISTOL AND "T" HANDLE SCREW DRIVERS

## SCREW DRIVER ATTACHMENT

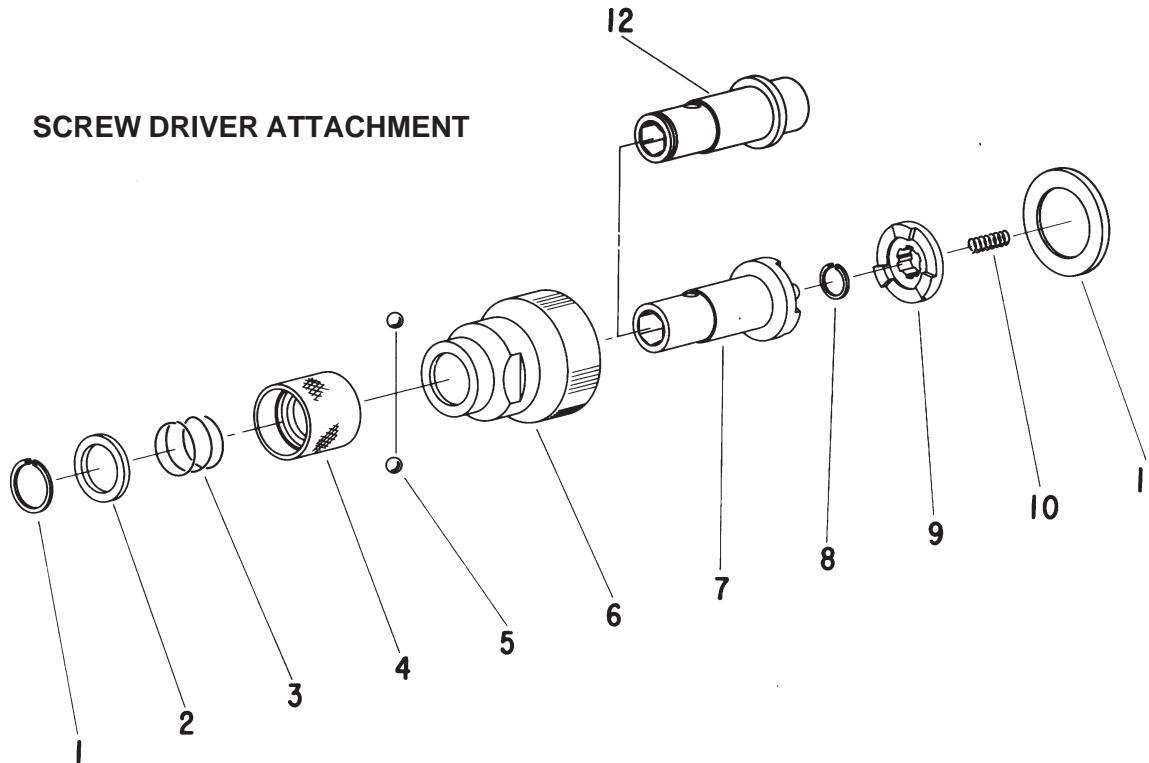
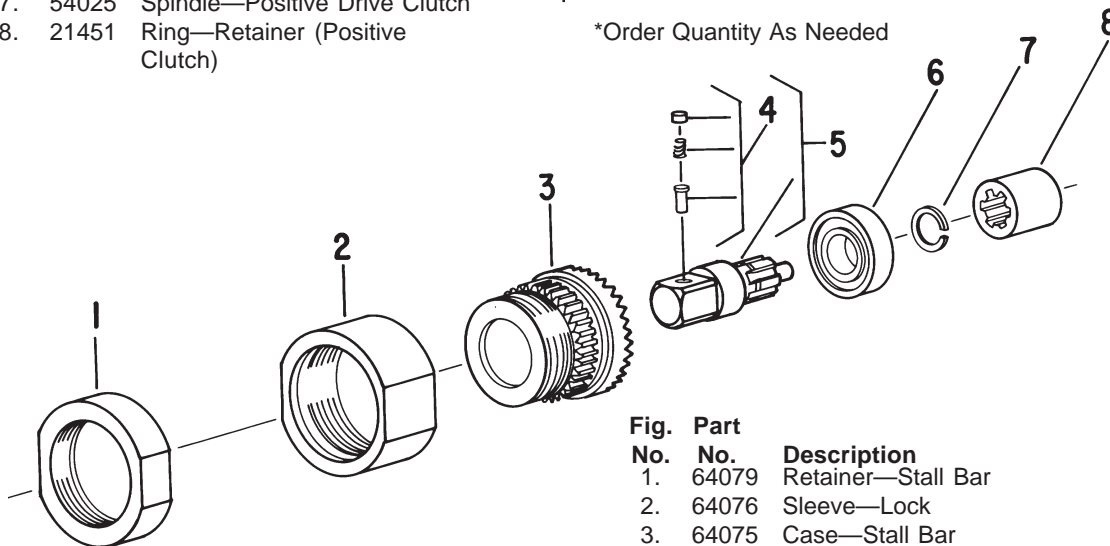

Fig. No.	Part No.	Description
1.	21754	Ring—Retainer
2.	54009	Ring—Guide
3.	41241	Spring
4.	54008	Retainer—Ball
5.	10291	Ball—Steel (2)*
6.	53023	Ass'y—Clutch Case
7.	54025	Spindle—Positive Drive Clutch
8.	21451	Ring—Retainer (Positive Clutch)

Fig. No.	Part No.	Description
9.	54028	Clutch—Driver Positive
10.	41242	Spring
11.	44796	Spacer
	53190	Ass'y—Complete Direct Drive
	53024	Ass'y—Complete Positive Drive
12.	54168	Spindle—Stall Drive (Direct Clutch)

\*Order Quantity As Needed



## #3 SERIES STALL BAR ATTACHMENT

Fig. No.	Part No.	Description
1.	64079	Retainer—Stall Bar
2.	64076	Sleeve—Lock
3.	64075	Case—Stall Bar
4.	33465	Ass'y—Socket Retainer (3/8" Sq. Dr.)
	43890	Ass'y—Socket Retainer (1/2" Sq. Dr.)
5.	64078	Spindle—Tool (1/2" Sq. Dr.)
	64077	Spindle—Tool (3/8" Sq. Dr.)
6.	10228	Bearing—Ball
7.	21781	Ring—Retainer
8.	64074	Connector

# PARTS LIST FOR NO. 3 SERIES NON-REVERSING "T" HANDLE DRILLS AND SCREWDRIVERS

## SERIAL "B"

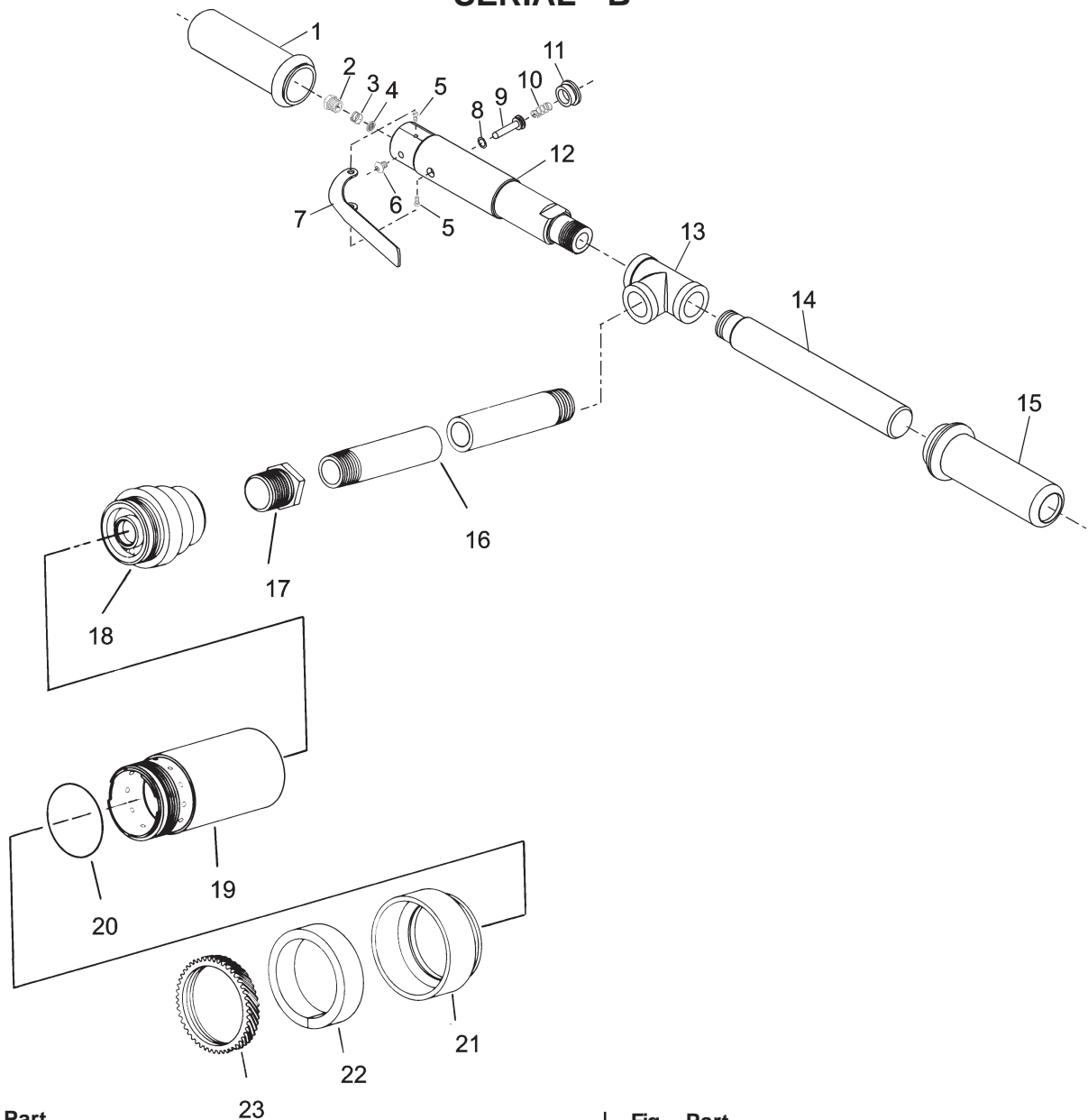

Fig. No.	Part No.	Description
1.	66880A	Cover
2.	44100	Bushing—Reducing
3.	21417	Spring
4.	30462	Screen
5.	06099	Screw (2)*
6.	66963	Screw
7.	35235	Lever—Handle
8.	65289	Ring—"O"
9.	63575	Stem—Valve
10.	21211	Spring
11.	66878	Cap
12.	67401	Ass'y—Handle and Extension (Includes Figs. 12 thru 14)
13.	40073	Straight—"Tee" 1/2"
14.	54708	Handle—Dead

Fig. No.	Part No.	Description
15.	67532	Grip
16.	40072	Extension
17.	40076	Bushing—Reducer
18.	54706	Adapter
19.	44792	Housing—Motor
20.	04206	Ring—"O"
21.	54156	Deflector
22.	14100	Liner—Deflector
23.	54182	Diffuser—Air
	67402	Ass'y—Tee Handle Complete (Includes Figs. 1 thru 15)

\*Order Quantity As Needed

Furnish Catalog, Serial, & Model Number When Ordering Parts



# PARTS LIST FOR NO. 3 SERIES REVERSING "T" HANDLE DRILLS AND SCREWDRIVERS SERIAL "B"

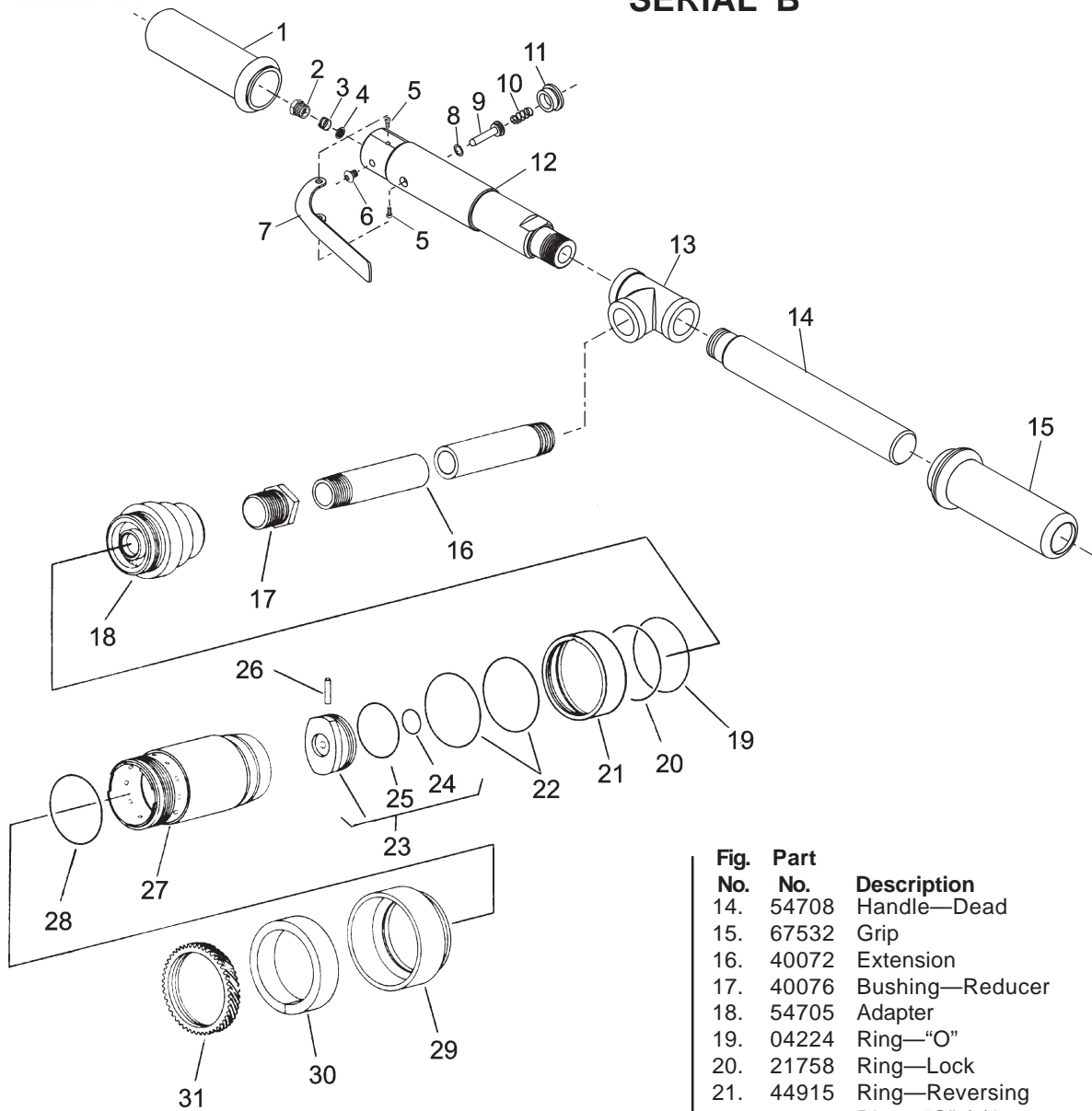

Fig. No.	Part No.	Description
1.	66880A	Cover
2.	44100	Bushing—Reducing
3.	21417	Spring
4.	30462	Screen
5.	06099	Screw (2)*
6.	66963	Screw
7.	35235	Lever—Handle
8.	65289	Ring—"O"
9.	63575	Stem—Valve
10.	21211	Spring
11.	66878	Cap
12.	67401	Ass'y—Handle and Extension (Includes Figs. 12 thru 14)
13.	40073	Straight—"Tee" 1/2"

Fig. No.	Part No.	Description
14.	54708	Handle—Dead
15.	67532	Grip
16.	40072	Extension
17.	40076	Bushing—Reducer
18.	54705	Adapter
19.	04224	Ring—"O"
20.	21758	Ring—Lock
21.	44915	Ring—Reversing
22.	04223	Ring—"O" (2)*
23.	53746	Ass'y—Valve Plate
24.	14309	Ring—"O"
25.	04222	Ring—"O"
26.	66122	Pin
27.	54146	Housing—Motor
28.	04206	Ring—"O"
29.	54156	Deflector
30.	14100	Liner—Deflector
31.	54182	Diffuser—Air
	67402	Ass'y—Tee Handle Complete (Includes Figs. 1 thru 15)

\*Order Quantity As Needed

Furnish Catalog, Serial, & Model Number  
When Ordering Parts

## SIoux TOOLS INC.

250 SNAP-ON DRIVE ■ PO BOX 1596 ■ MURPHY, NC 28906 ■ USA ■

Printed In U.S.A.

This pdf incorporates the following model numbers:

3T2303