



## PARTS LIST FOR NO. 3 SERIES ANGLE NUTRUNNERS, DRILLS AND SCREWDRIVERS (STALL DRIVE) AND LEVER HANDLE DRILLS AND SCREWDRIVERS SERIAL "E"

### NON-REVERSING HANDLE ASSEMBLY

Fig. No.	Part No.	Description
1.	54156	Deflector
2.	04206	Ring—"O"
3.	43758	Ass'y—Handle & Motor Housing (Includes Fig 10 & 21)
	43577	Ass'y—Handle & Motor Housing (Includes Fig 4-23)
4.	11560	Lever
5.	43774	Ass'y—Screw & "O" Ring
6.	14369	Ring—"O" (2)*
7.	44786	Insert
8.	41216	Spring—Reset
9.	43775	Ass'y—Valve Seat & "O" Ring
10.	14394	Ring—"O"
11.	43776	Ass'y—Valve
12.	25957	Washer
13.	04205	Valve
14.	41217	Spring—Throttle
15.	44100	Bushing—Reducing 3/8" to 1/4"
17.	33993	Ass'y—Air Screen

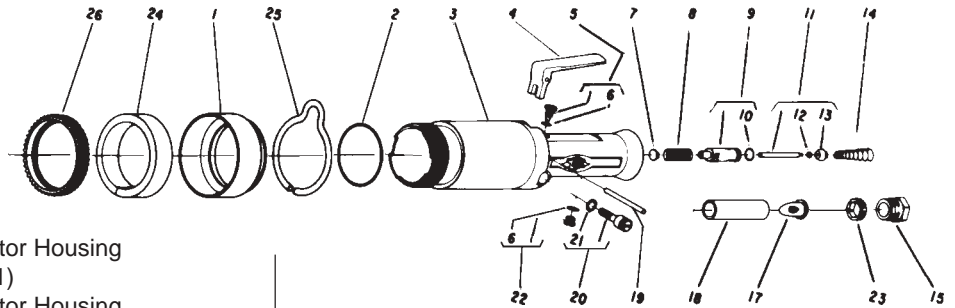

Fig. No.	Part No.	Description
18.	44787	Tube
19.	30606	Pin—Dowel
20.	43777	Ass'y—Air Regulator Screw & "O" Ring
21.	14291	Ring—"O"
22.	44253	Ass'y—Oiler Screw & "O" Ring
23.	44997	Retainer
24.	14100	Liner—Deflector
25.	41238	Bail
26.	54182	Diffuser—Air

### REVERSIBLE HANDLE ASSEMBLY

Fig. No.	Part No.	Description
1.	54156	Deflector
2.	04206	Ring—"O"
3.	§	Housing—Motor
5.	53746	Ass'y—Valve Plate (Includes Fig. 8) (Serial "B" & Up To Serial "D")
	63009	Ass'y—Valve Plate (Serial "D" & Up)
6.	34694	Pin
7.	04222	Ring—"O"
8.	14390	Ring—Quad (Up To Serial "B")
	14309	Ring—"O" (Serial "B" & Up)
9.	04223	Ring—"O" (2)*
10.	44915	Ring—Reversing
11.	21758	Ring—Lock
12.	§	Handle
13.	11560	Lever
14.	43774	Ass'y—Screw & "O" Ring
15.	14369	Ring—"O" (2)*
16.	44786	Insert
17.	41216	Spring—Reset
18.	43775	Ass'y—Valve Seat & "O" Ring
19.	14394	Ring—"O"
20.	43776	Ass'y—Valve
21.	25957	Washer
22.	04205	Valve

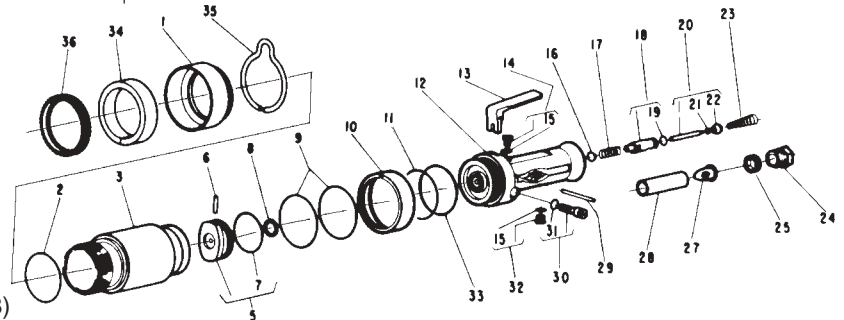

Fig. No.	Part No.	Description
23.	41217	Spring—Throttle
24.	44100	Bushing—Reducing 3/8" to 1/4"
25.	44997	Retainer
27.	33993	Ass'y—Air Screen
28.	44787	Tube
29.	30606	Pin—Dowel
30.	43777	Ass'y—Air Regulator Screw & "O" Ring
31.	14291	Ring—"O"
32.	44253	Ass'y—Oiler Screw & "O" Ring
33.	04224	Ring—"O"
34.	14100	Liner—Deflector
35.	41238	Bail
36.	54182	Diffuser—Air

§ Figures 3 & 12 available only as an Ass'y No. 12347 which also includes Figures 19 & 31 & New Style Figure 5, or 53160 which includes Figures 3-33.

# SIoux TOOLS INC.

250 SNAP-ON DRIVE ■ PO BOX 1596 ■ MURPHY, NC 28906 ■ USA ■

\*Order Quantity As Required  
FURNISH CATALOG, SERIAL, AND MODEL  
NUMBER WHEN ORDERING PARTS

Printed In U.S.A.

## NON-REVERSING MOTOR ASSEMBLY

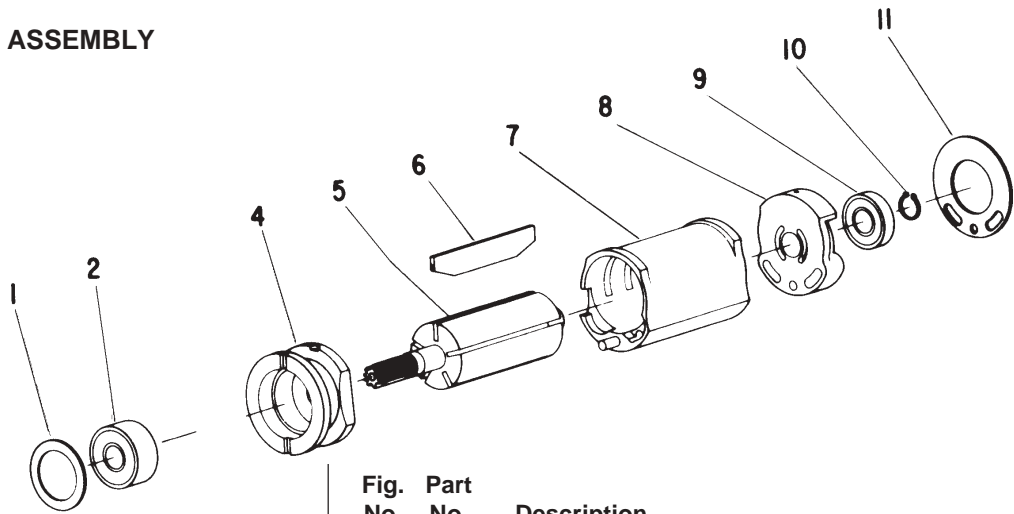

Fig. No.	Part No.	Description
1.	35227	Washer
2.	10221	Bearing—Ball
4.	13226	Plate—Front End (Includes Fig. 2)
5.	44870	Rotor (1800 RPM)
	54675	Rotor (360, 2250 RPM)
	54676	Rotor (600, 850, 1200 RPM)
6.	43888	Ass'y—Rotor Vane (Set of 5)
7.	44869	Cylinder
8.	13227	Plate—Rear End

Fig. No.	Part No.	Description
9.	10241	Bearing—Ball
10.	21534	Ring—Retainer
11.	14794	Gasket
	43781	Ass'y—Complete Motor (600, 850, 1200 RPM)
	43782	Ass'y—Complete Motor (1800 RPM)
	43783	Ass'y—Complete Motor (360, 2250 RPM)

## REVERSING MOTOR ASSEMBLY

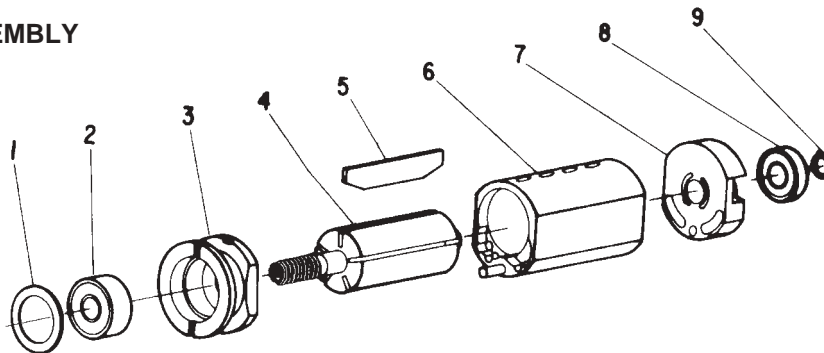

Fig. No.	Part No.	Description
1.	35227	Washer
2.	10221	Bearing—Ball
3.	13226	Plate—Front End (Includes Fig. 2)
4.	44870	Rotor (1400 RPM)
	54675	Rotor (300, 1875 RPM)
	54676	Rotor (480, 700, 1000 RPM)
5.	43888	Ass'y—Rotor Vane (Set of 5)
6.	54049	Cylinder
7.	13246	Plate—Rear End

Fig. No.	Part No.	Description
8.	10241	Bearing—Ball
9.	21534	Ring—Retainer
	53057	Ass'y—Complete Motor (1400 RPM)
	53907	Ass'y—Complete Motor (480, 700, 1000 RPM)
	53908	Ass'y—Complete Motor (300, 1875 RPM)

\*Order Quantity As Required  
**FURNISH CATALOG, SERIAL, AND MODEL  
 NUMBER WHEN ORDERING PARTS**

# SINGLE REDUCTION GEAR CASE

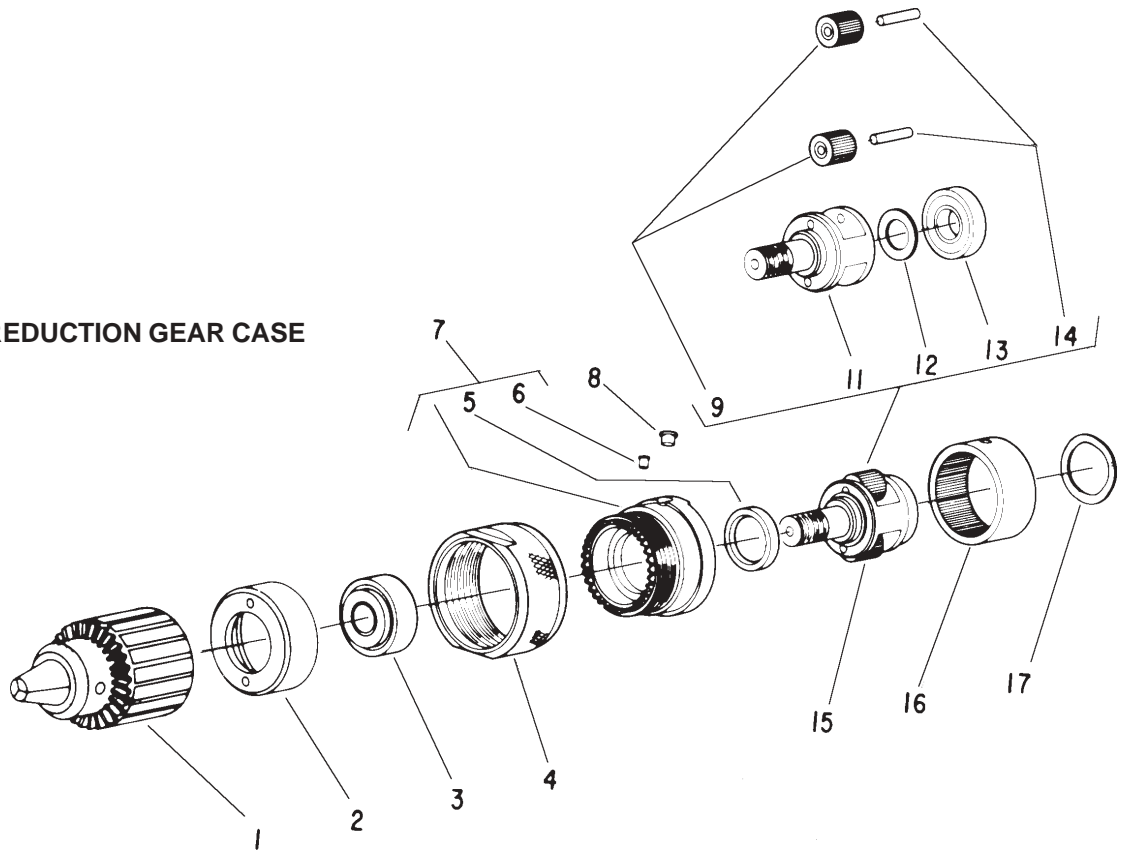

Fig. No.	Part No.	Description
1.	21002	Chuck (3/8" Cap.)
	08310	Screw—L.H. (Reversing Units)(Serial "C" & Up)
	30011	Key—Chuck
2.	44914	Retainer
3.	10198	Bearing—Ball
4.	44798	Sleeve—Lock
5.	30258	Seal—Oil
6.	30375	Fitting—Grease
7.	44799	Case—Gear
8.	44795	Pin
9.	19327	Ass'y—Gear & Bearing (1800, 1400 RPM)(2)*
	19324	Ass'y—L.H. & Bearing (2250, 1875 RPM)(2)*
11.	22656	Spindle—Chuck (Reversing)(1400 RPM) (Includes Chuck Retaining Screw)
	44808	Spindle—Chuck (Non-Reversing)(1800 RPM)
	22657	Spindle—Chuck (Reversing)(1875 RPM) (Includes Chuck Retaining Screw)
	22640	Spindle—Chuck (Non-Reversing)(2250 RPM)
12.	25976	Washer
13.	10203	Bearing—Ball

Fig. No.	Part No.	Description
14.	30467	Pin (2)*
15.	53724	Ass'y—2nd Planetary Gear (1400 RPM) (Reversing)( Includes 08310 Screw)
	43873	Ass'y—2nd Planetary Gear (1800 RPM) (Non-Reversing)
	53723	Ass'y—2nd Planetary Gear (1875 RPM) (Reversing)(Includes 08310 Screw)
	43872	Ass'y—2nd Planetary Gear (2250 RPM) (Non-Reversing)
16.	19208	Gear—Ring
17.	41236	Washer
	53731	Ass'y—Gear Case(Reversing)(1400 RPM)
	43875	Ass'y—Gear Case (Non-Reversing)(1800 RPM)
	53730	Ass'y—Gear Case (Reversing)(1875 RPM)
	43876	Ass'y—Gear Case (Non-Reversing)(2250 RPM)

\*Order Quantity As Required  
**FURNISH CATALOG, SERIAL, AND MODEL  
 NUMBER WHEN ORDERING PARTS**

# DOUBLE REDUCTION GEAR CASE

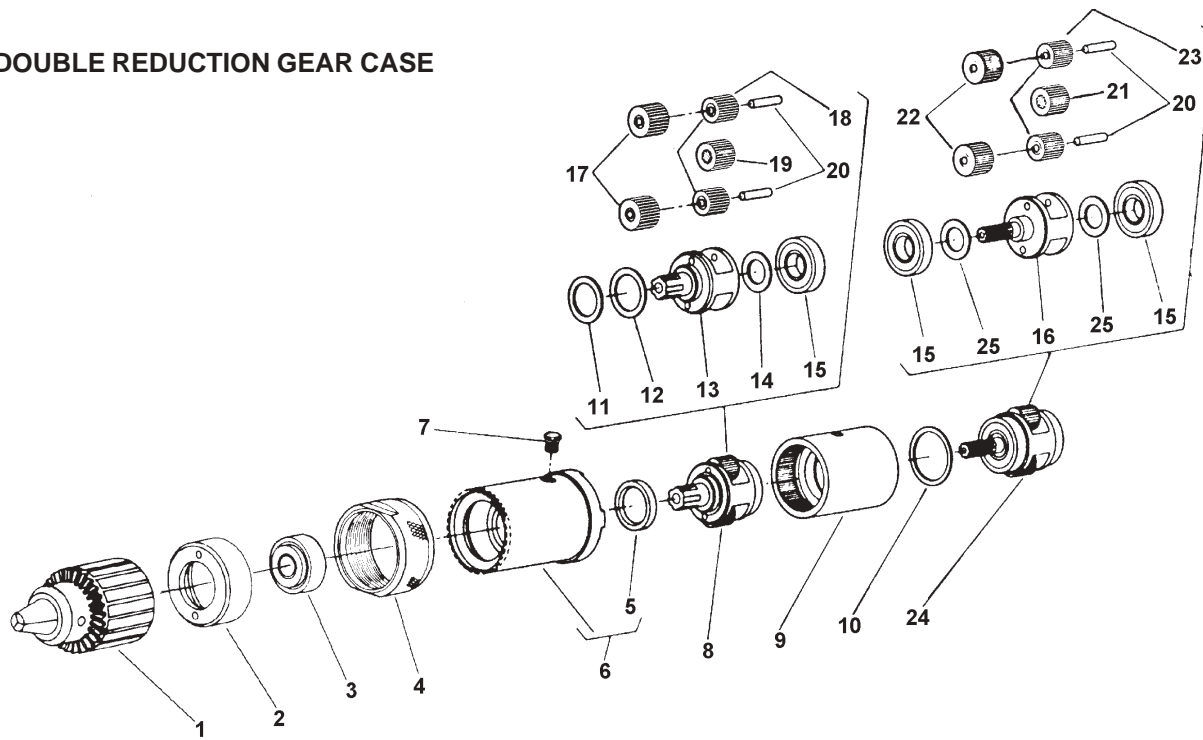

Fig. No.	Part No.	Description	
1.	21002	Chuck (3/8" Cap.)	
	21137	Chuck (1/2" Cap.)	
	08310	Screw—L.H. (Reversing Units)(Serial "D" & Up)	
	30011	Key—Chuck	
2.	44914	Retainer	
3.	10198	Bearing—Ball	
4.	44798	Sleeve—Lock	
5.	30258	Seal—Oil	
6.	44800	Case—Gear	
7.	44797	Lock—Screw	
8.	53724	Ass'y—2nd Planetary Reduction (Reversing)(300 RPM)(Includes 08310 Screw)	
	43873	Ass'y—2nd Planetary Reduction (Non-Reversing)(360 RPM)	
	53723	Ass'y—2nd Planetary Reduction (Reversing)(480 RPM)(Includes 08310 Screw)	
	43872	Ass'y—2nd Planetary Reduction (Non-Reversing)(600 RPM)	
	53725	Ass'y—2nd Planetary Reduction (Reversing)(700 RPM)(Includes 08310 Screw)	
	53003	Ass'y—2nd Planetary Reduction (Non-Reversing)(850 RPM)	
	53722	Ass'y—2nd Planetary Reduction (Reversing)(1000 RPM)(Includes 08310 Screw)	
	43871	Ass'y—2nd Planetary Reduction (Non-Reversing)(1200 RPM)	
	9.	19207	Gear—Ring
	10.	21531	Ping—Lock
11.	21524	Ring—Retainer (700 & 850 RPM)	
	21753	Ring—Retainer (1000 & 1200 RPM)	
12.	35260	Washer (1000 & 1200 RPM)	
13.	22656	Spindle—Chuck (Reversing)(300 RPM)(Includes Chuck Retaining Screw)	
	44808	Spindle—Chuck (Non-Reversing)(360 RPM)	
	22657	Spindle—Chuck (Reversing)(480 RPM)(Includes Chuck Retaining Screw)	
	22640	Spindle—Chuck (Non-Reversing)(600 RPM)	

Fig. No.	Part No.	Description
	22659	Spindle—Chuck (Reversing)(700 RPM)(Includes Chuck Retaining Screw)
	54004	Spindle—Chuck (Non-Reversing)(850 RPM)
	22658	Spindle—Chuck (Reversing)(1000 RPM)(Includes Chuck Retaining Screw)
	44810	Spindle—Chuck (Non-Reversing)(1200 RPM)
14.	25976	Washer
15.	10203	Bearing—Ball (3)*
16.	44961	Carrier—Pinion Planetary (300 & 360 RPM)
	44868	Carrier—Pinion Planetary (480 & 600 RPM)
	44806	Carrier—Pinion Planetary (700 & 850 RPM)
	44805	Carrier—Pinion Planetary (1000 & 1200 RPM)
17.	19327	Ass'y—Gear & Bearing (300 & 360 RPM)(2)*
	19324	Ass'y—Gear & Bearing (480 & 600 RPM)(2)*
18.	19326	Ass'y—Gear & Bearing (700 & 850 RPM)(2)*
	19325	Ass'y—Gear & Bearing (1000 & 1200 RPM)(2)*
19.	19205	Gear—Pinion (700 & 850 RPM)
	19206	Gear—Pinion (1000 & 1200 RPM)
20.	30467	Pin (300, 360, 480, 600, 700 & 850 RPM)(4)*
	30369	Pin (1000 & 1200 RPM)(4)*
21.	19205	Gear—Pinion (480, 600, 700 & 850 RPM)
	19206	Gear—Pinion (1000 & 1200 RPM)
22.	19324	Ass'y—Gear & Bearing (300 & 360 RPM)(2)*
23.	19326	Ass'y—Gear & Bearing (480, 600, 700 & 850 RPM)(2)*
	19325	Ass'y—Gear & Bearing (1000 & 1200 RPM)(2)*
	43882	Ass'y—1st Planetary Gear (330 & 360 RPM)
24.	43655	Ass'y—1st Planetary Gear (480 & 600 RPM)
	43587	Ass'y—1st Planetary Gear (700 & 850 RPM)
	43585	Ass'y—1st Planetary Gear (1000 & 1200 RPM)
25.	35135	Washer (2)*

\*Order Quantity As Required  
**FURNISH CATALOG, SERIAL, AND MODEL NUMBER WHEN ORDERING PARTS**

## SINGLE REDUCTION GEAR CASE

Fig. No.	Part No.	Description
1.	10251	Bearing—Ball
2.	44798	Sleeve—Lock
3.	44799	Case—Gear
4.	30258	Seal—Oil
5.	43584	Ass'y—Second Planetary Gear (1400, 1800 RPM)
	43582	Ass'y—Second Planetary Gear (1875, 2250 RPM)
6.	19208	Gear—Ring
7.	30375	Fitting—Grease
8.	44795	Pin
9.	19327	Ass'y—Gear & Bearing (1400, 1800 RPM)(2)*
	19324	Ass'y—Gear & Bearing (1875, 2250 RPM)(2)*
11.	44804	Carrier—Second Planet (1400, 1800 RPM)
	44803	Carrier—Second Planet (1875, 2250 RPM)
12.	25976	Washer
13.	10203	Bearing—Ball
14.	30467	Pin (2)*
15.	41236	Washer

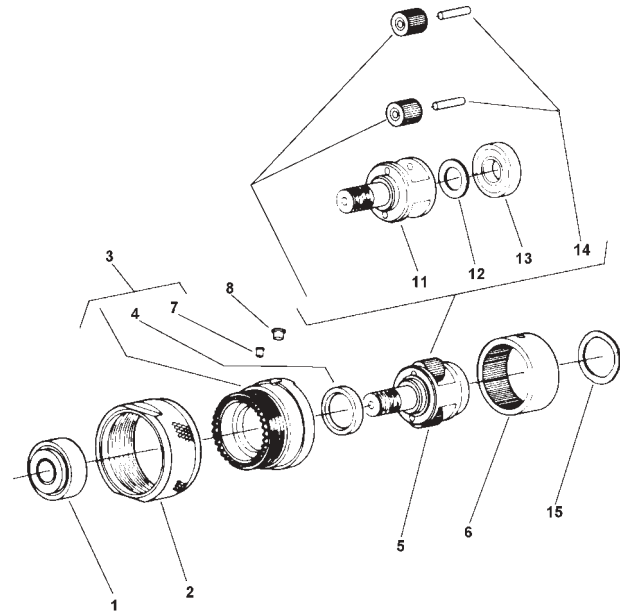

## DOUBLE REDUCTION GEAR CASE

Fig. No.	Part No.	Description
1.	10251	Bearing—Ball
2.	44798	Sleeve—Lock
3.	44800	Case—Gear
4.	30258	Seal—Oil
5.	43582	Ass'y—2nd Planetary Gear (300, 360, 480, 600 RPM)
	43583	Ass'y—2nd Planetary Gear (700, 850 RPM)
	43581	Ass'y—2nd Planetary Gear (1000, 1200 RPM)
6.	19207	Gear—Ring
7.	21531	Ring—Lock
8.	43586	Ass'y—1st Planetary Gear (300, 360 RPM)
	43655	Ass'y—1st Planetary Gear (480, 600 RPM)
	43587	Ass'y—1st Planetary Gear (700, 850 RPM)
	43585	Ass'y—1st Planetary Gear (1000, 1200 RPM)
9.	44797	Lock—Screw
11.	21524	Ring—Retainer (700, 850 RPM)
	21753	Ring—Retainer (1000, 1200 RPM)
12.	35260	Washer (1000, 1200 RPM)
13.	44803	Carrier—Second Planetary (300, 360, 480, 600 RPM)
	44802	Carrier—Second Planetary (700, 850 RPM)
	44801	Carrier—Second Planetary (1000, 1200 RPM)
14.	25976	Washer
15.	10203	Bearing—Ball (3)*
16.	44807	Carrier—Pinion Planetary (300, 360 RPM)
	44868	Carrier—Pinion Planetary (480, 600 RPM)
	44806	Carrier—Pinion Planetary (700, 850 RPM)
	44805	Carrier—Pinion Planetary (1000, 1200 RPM)

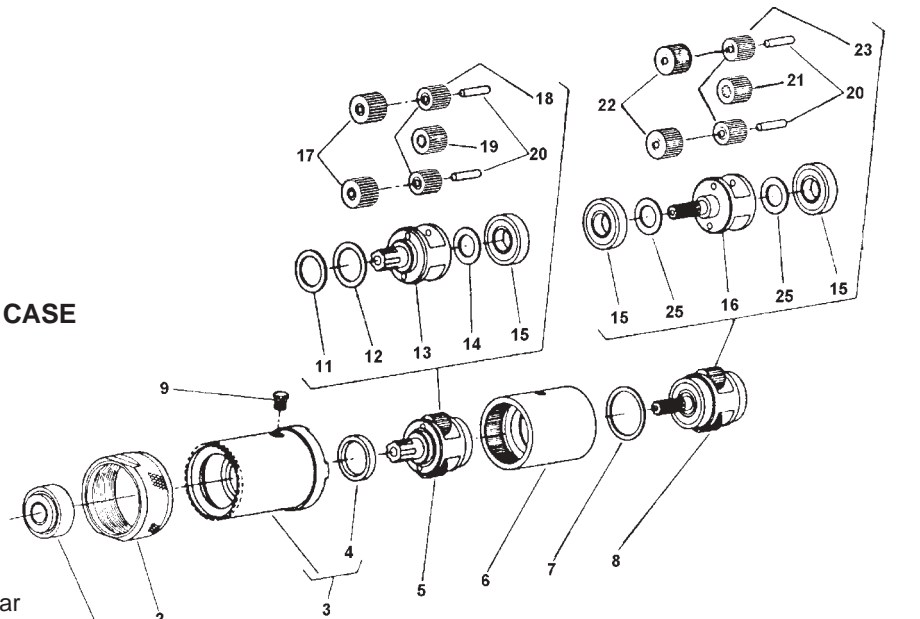
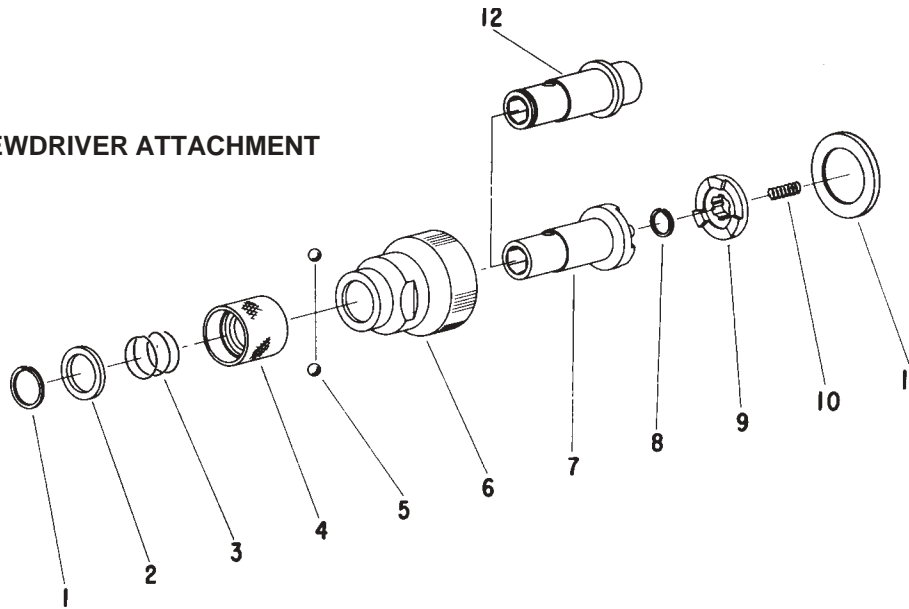

Fig. No.	Part No.	Description
17.	19324	Ass'y—Gear & Bearing (300, 360, 480, 600 RPM)(2)*
18.	19326	Ass'y—Gear & Bearing (700, 850 RPM)(2)*
	19325	Ass'y—Gear & Bearing (1000, 1200 RPM)(2)*
19.	19205	Gear—Pinion (700, 850 RPM)
	19206	Gear—Pinion (1000, 1200 RPM)
20.	30467	Pin (300, 360, 480, 600, 700, 850 RPM)(4)*
	30369	Pin (1000, 1200 RPM)(4)*
21.	19205	Gear—Pinion (480, 600, 700, 850 RPM)
	19206	Gear—Pinion (1000, 1200 RPM)
22.	19324	Ass'y—Gear & Bearing (300, 360 RPM)(2)*
23.	19326	Ass'y—Gear & Bearing (480, 600, 700, 850 RPM)(2)*
	19325	Ass'y—Gear & Bearing (1000, 1200 RPM)(2)*
25.	35135	Washer (2)*

\*Order Quantity As Required

**FURNISH CATALOG, SERIAL, AND MODEL NUMBER WHEN ORDERING PARTS**

## SCREWDRIVER ATTACHMENT



**Fig. Part**

No.	Part No.	Description
1.	21754	Ring—Retaining
2.	54009	Ring—Guide
3.	41241	Spring
4.	54008	Retainer—Ball
5.	10291	Ball—Steel (2)*
6.	53023	Ass'y—Clutch Case
7.	54025	Spindle—Positive Drive Clutch
8.	21451	Ring—Retaining (Positive Clutch)
9.	54028	Driver—Positive Clutch
10.	41242	Spring
11.	44796	Spacer
12.	54168	Spindle—Stall Drive (Direct Clutch)
	53190	Ass'y—Complete Direct Drive
	53024	Ass'y—Complete Positive Drive

\*Order Quantity As Required  
**FURNISH CATALOG, SERIAL, AND MODEL  
 NUMBER WHEN ORDERING PARTS**

### NO. 3 SERIES SHORT HIGH TORQUE ANGLE

Fig. No.	Part No.	Description
1.	21137	Chuck—1/2" Cap.
	08310	Screw—L.H. (Reversing Units) (Serial "C" & Up)
	30011	Key—Chuck
2.	44813	Retainer—Bearing
3.	22661	Spindle—Tool (Non-Reversing) (Includes Chuck Retaining Screw)
4.	43596	Ass'y—Tool Spindle
5.	43890	Ass'y—Socket Retainer
6.	10265	Bearing—Ball
7.	19722	Gear—Matched Set, Spiral Bevel Gear & Pinion
8.	21781	Ring—Retaining
9.	43846	Ass'y—Angle Head
10.	10012	Bearing—Needle
11.	30356	Fitting—Grease
12.	10081	Bearing—Needle
13.	34808	Bearing—Spacer
14.	10239	Bearing—Ball
15.	44775	Retainer—Bearing
16.	44960	Connector—Short
17.	44796	Spacer
18.	21754	Ring—Retaining
19.	54009	Ring—Guide
20.	41241	Spring
21.	54008	Retainer—Ball

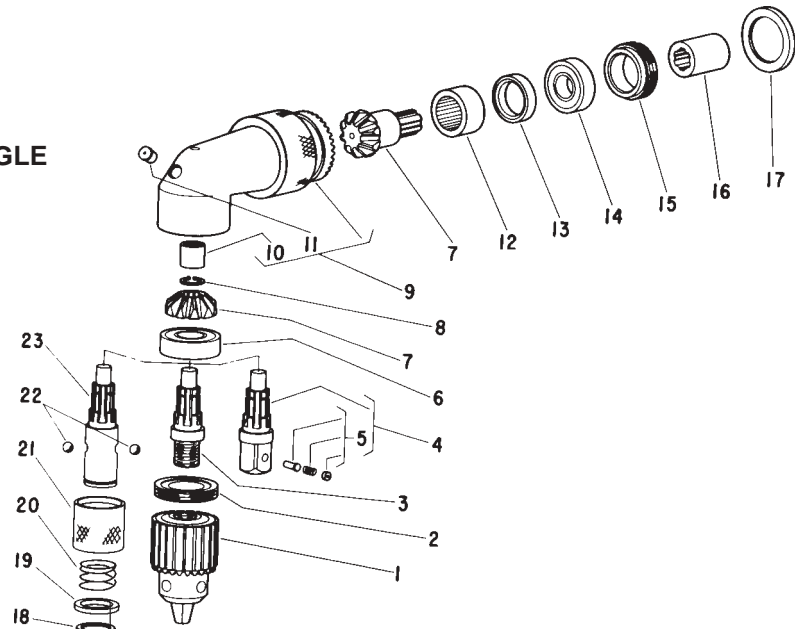
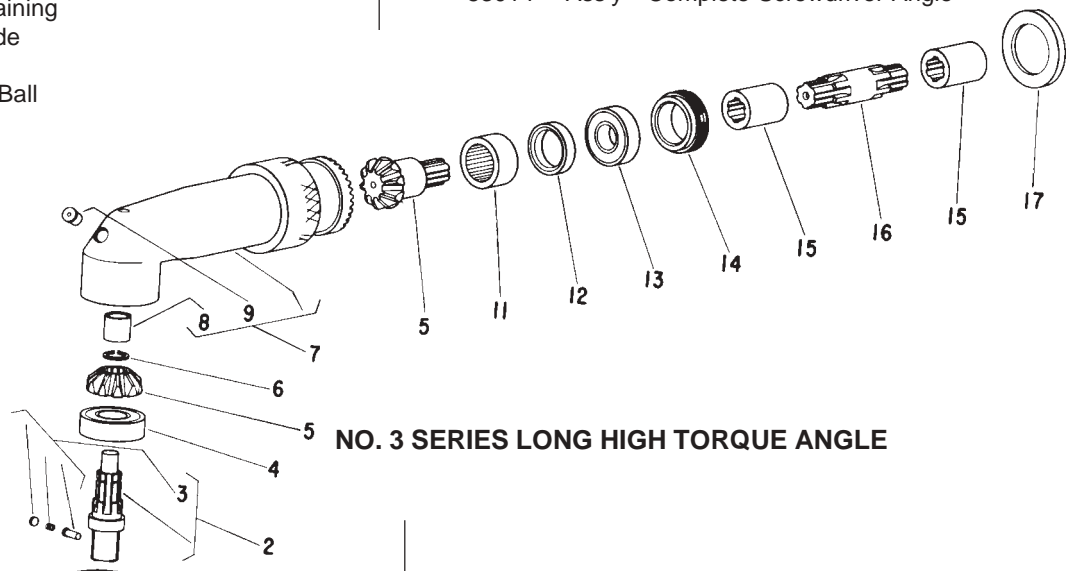

Fig. No.	Part No.	Description	
	22.	10291	Ball—Steel
	23.	22668	Spindle—7/16" Hex
	43828	Ass'y—Complete Drill Angle (Non-Reversing)	
	53729	Ass'y—Complete Drill Angle (Reversing)	
	43771	Ass'y—Complete Nutrunner Angle	
	53014	Ass'y—Complete Screwdriver Angle	



### NO. 3 SERIES LONG HIGH TORQUE ANGLE

Fig. No.	Part No.	Description
1.	44813	Retainer—Bearing
2.	43595	Ass'y—Tool Spindle 3/8" Drive
	43596	Ass'y—Tool Spindle 1/2" Drive
3.	33465	Ass'y—Socket Retainer 3/8" Square
	43890	Ass'y—Socket Retainer 1/2" Square
4.	10265	Bearing—Ball
5.	19722	Gear—Matched Set, Spiral Bevel Gear & Pinion
6.	21781	Ring—Retaining
7.	43796	Ass'y—Angle Head (Long)
8.	10012	Bearing—Needle
9.	30356	Fitting—Grease
11.	10081	Bearing—Needle

Fig. No.	Part No.	Description
12.	34808	Bearing—Spacer
13.	10239	Bearing—Ball
14.	44775	Retainer—Bearing
15.	44811	Connector—Long (2)*
16.	44812	Connector—Spindle
17.	44796	Spacer
	43598	Ass'y—Complete Long Heavy Duty Angle Head

\*Order Quantity As Required  
**FURNISH CATALOG, SERIAL, AND MODEL  
 NUMBER WHEN ORDERING PARTS**



### NO. 3 SERIES SHORT LOW TORQUE ANGLE

Fig. No.	Part No.	Description
1.	21133	Chuck
	06605	Screw—RH Thread (Reversing Units) (Serials A-D)
	57250R	Screw—LH Thread (Reversing Units) (Serial E)
	30002	Key—Chuck
2.	44776	Retainer—Bearing
3.	22651	Spindle—Tool
4.	43564	Ass'y—Tool Spindle (3/8" Sq.)
5.	33465	Ass'y—Socket Retainer (3/8" Sq.)
6.	10226	Bearing—Ball (2)*
7.	19723	Gear—Matched Set, Spiral Bevel Gear & Pinion
8.	21545	Ring—Retaining
9.	43795	Ass'y—Angle Head
10.	10012	Bearing—Needle
11.	30356	Fitting—Grease
12.	10049	Bearing—Needle
13.	35214	Washer
14.	44775	Retainer—Bearing
15.	44960	Connector—Short
16.	44796	Spacer
17.	44027	Retainer—Finder
18.	21377	Spring
19.	44036	Retainer—Bearing
20.	25854	Ring—Ball Retainer

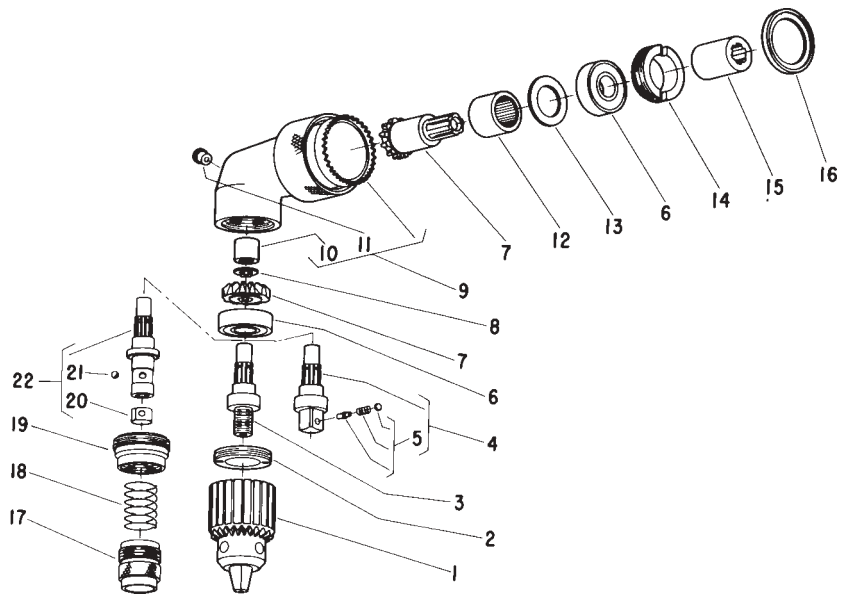
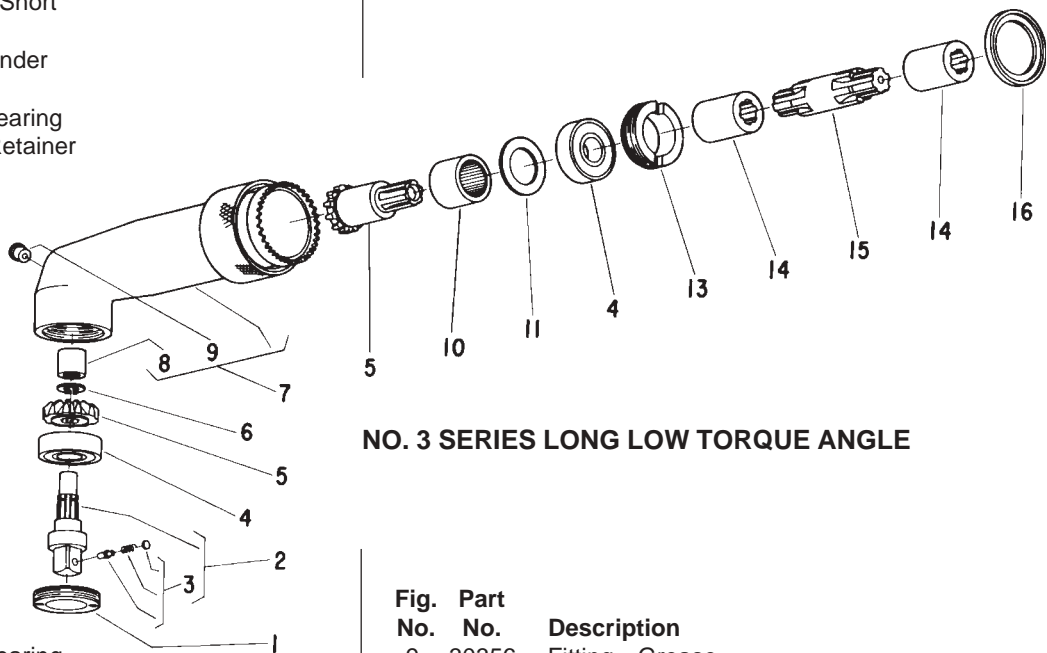

Fig. No.	Part No.	Description
21.	10902	Ball—Steel
22.	43562	Ass'y—1/4" Hex Drive Socket
§	43827	Ass'y—Complete Drill Angle (Non-Reversing)
	43594	Ass'y—Complete Nut Runner Angle
	53011	Ass'y—Complete Screw Driver Angle



### NO. 3 SERIES LONG LOW TORQUE ANGLE

Fig. No.	Part No.	Description
1.	44776	Retainer—Bearing
2.	43564	Ass'y—Tool Spindle
3.	33465	Ass'y—Socket Retainer
4.	10226	Bearing—Ball (2)*
5.	19723	Gear—Matched Set, Spiral Bevel Gear & Pinion
6.	21545	Ring—Retaining
7.	43794	Ass'y—Angle Head
8.	10012	Bearing—Needle

Fig. No.	Part No.	Description
9.	30356	Fitting—Grease
10.	10049	Bearing—Needle
11.	35214	Washer
13.	44775	Retainer—Bearing
14.	44811	Connector—Long (2)*
15.	44812	Connector—Spindle
16.	44796	Spacer
	43659	Ass'y—Complete Long Light Duty Angle Head

**SIoux TOOLS INC.**

250 SNAP-ON DRIVE ■ PO BOX 1596 ■ MURPHY, NC 28906 ■ USA ■

\*Order Quantity As Required  
FURNISH CATALOG, SERIAL, AND MODEL NUMBER WHEN ORDERING PARTS

Printed In U.S.A.