

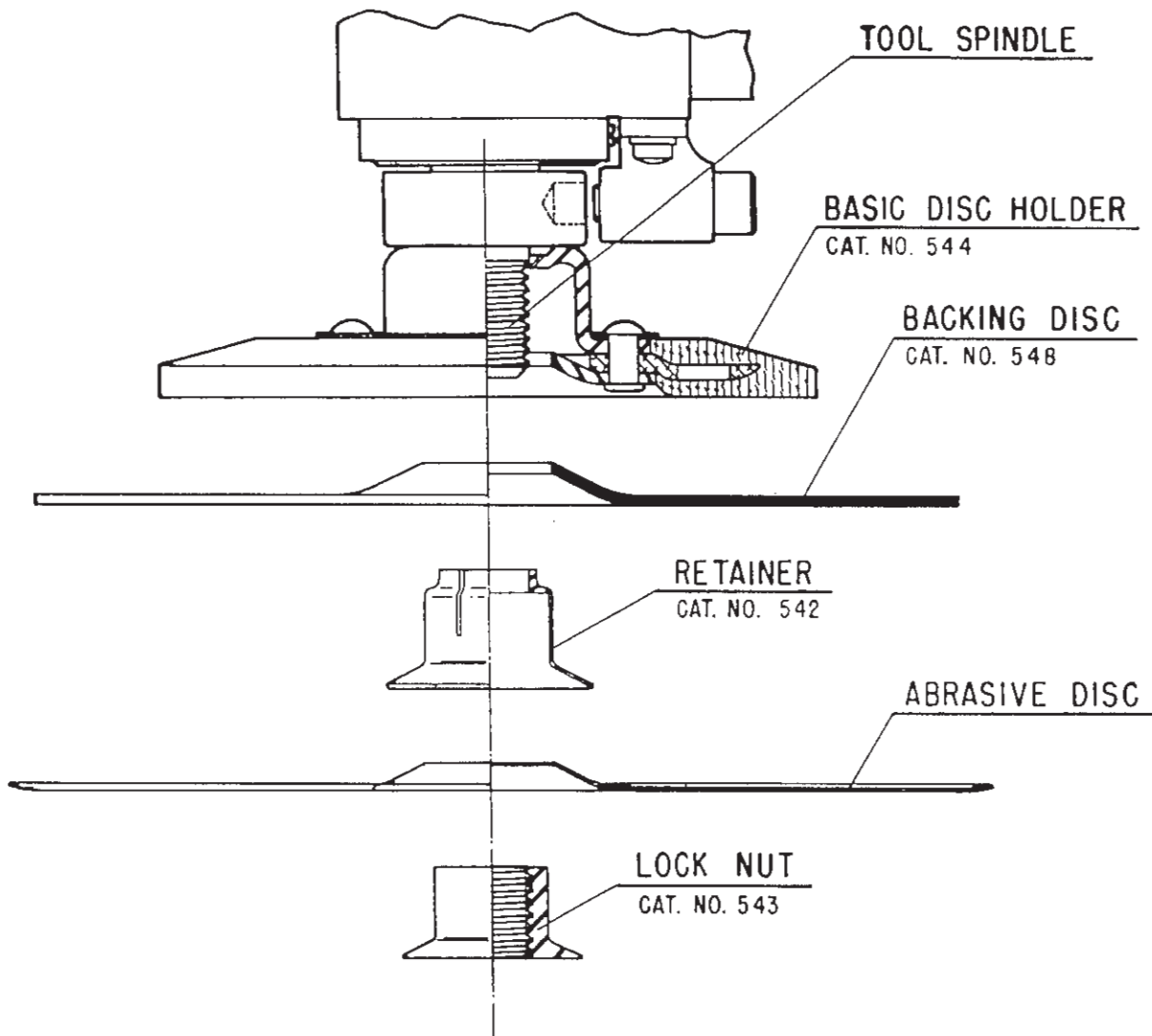

INSTRUCTIONS FOR No. 544 BACKING PAD ASSEMBLY



Place the Basic Disc Holder and Backing Disc (Cat. No. 548) on the tool spindle in that order. Push the retainer (Cat. No. 542) down on the spindle, through the Disc (Cat. No. 548) and into Basic Disc Holder, the Retainer (Cat. No. 542) will now hold these parts securely on the spindle ready for the installation of abrasive disc and lock nut (Cat. No. 543).

To replace the Backing Disc (Cat. No. 548), pull it off with the retainer (Cat. No. 542) and replace in reverse order.

(Basic Disc Holder No. 544 includes No. 542 Retainer and No. 543 Lock Nut).



**SIoux
TOOLS INC.**

2901 FLOYD BOULEVARD ■ SIOUX CITY, IOWA 51102 ■

PRINTED IN U.S.A.

This pdf incorporates the following model numbers:

544

545

545H