



## PARTS LIST FOR NO. 2 SERIES MULTI-ASSEMBLY TOOLS AIR SCREWDRIVERS, NUTRUNNERS, AND DRILLS (SERIALS STARTING WITH "J", "K", & "L")

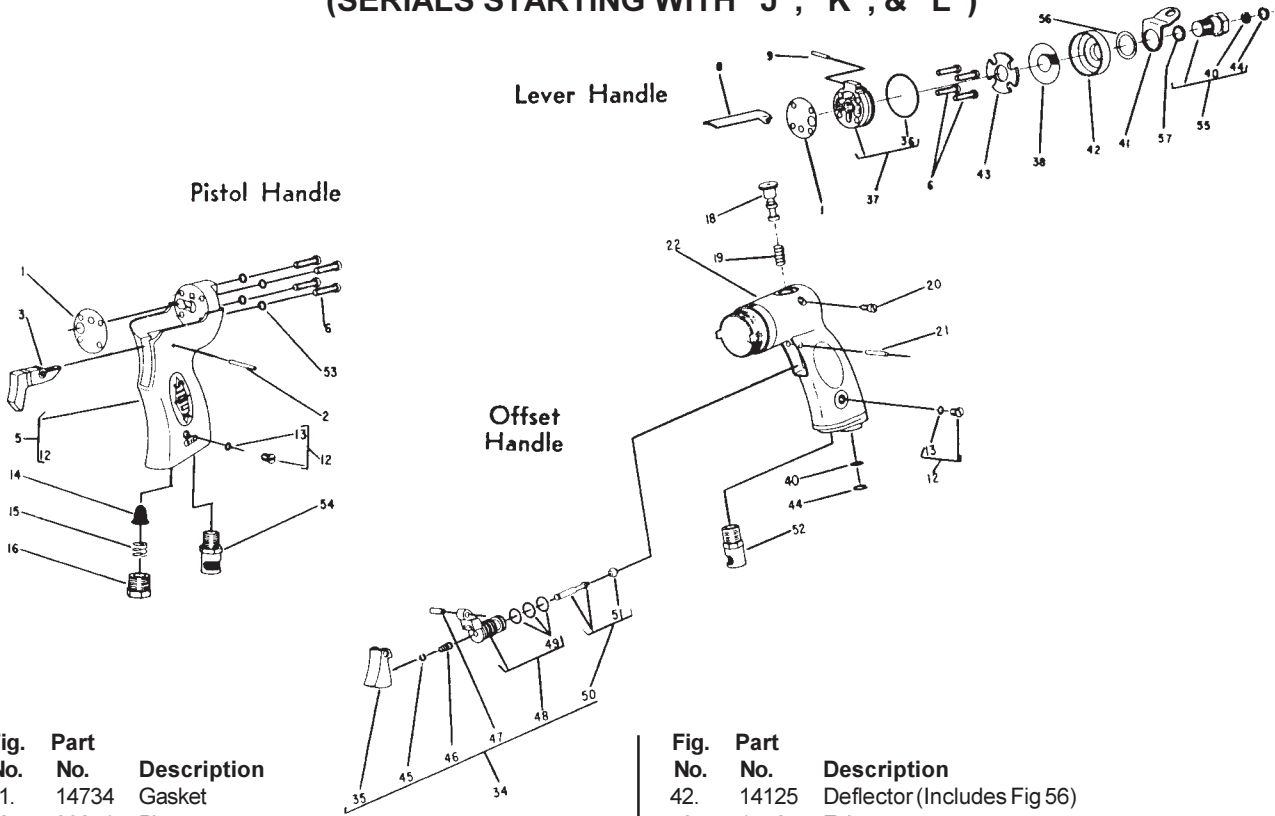

Fig. No.	Part No.	Description
1.	14734	Gasket
2.	30251	Pin
3.	33599	Trigger
5.	33602	Handle
6.	07140	Screw (4)*
8.	25988	Lever—Valve
9.	30362	Pin—Roll
12.	44253	Screw—Oiler
13.	14369	Ring—"O"
14.	33993	Screen—Air (1 Piece Pistol Handle)
15.	21417	Spring (1 Piece Pistol Handle)
16.	44100	Bushing (1 Piece Pistol Handle)
18.	44426	Spool—Valve (Reversing Only)(Non-Locking)
	44316	Spool—Valve (Reversing Only)(Locking)
19.	21427	Spring (Reversing Only)
20.	06502	Screw—Retaining
21.	30322	Groove Pin
22.	43628	Ass'y—Handle (Reversing) (Includes Fig's 12, 40, 44 & 52)
	43629	Ass'y—Handle (Non-Reversing) (Includes Fig's 12, 40, 44 & 52)
34.	53245	Ass'y—Adjustable Throttle Valve
35.	53182	Ass'y—Adjustable Trigger
36.	14313	Ring—"O"
37.	53945	Ass'y—End Cap & "O" Ring (Includes Fig 55)
38.	30470	Screen
40.	30463	Screen
41.	35192	Bail

Fig. No.	Part No.	Description
42.	14125	Deflector (Includes Fig 56)
43.	14764	Felt
44.	21541	Ring—Retainer
45.	21542	Ring—Retainer
46.	21401	Spring
47.	44754	Bushing
48.	53258	Ass'y—Valve Body & "O" Rings
49.	14312	Ring—"O" (3)*
50.	53246	Ass'y—Plunger Valve
51.	14325	Valve
52.	53326	Ass'y—Silencer (Offset Handle)
53.	09724	Washer—Lock (4)*
54.	43543	Ass'y—Silencer (Pistol Handle)
55.	43154	Ass'y—Adapter & Screen (Serial No's Up To "K")
	53942	Ass'y—Adapter & Screen (Includes Fig 57)(Serial "K")
56.	35260	Washer
57.	14312	Ring—"O"

**COMPLETE ASSEMBLY**

33637	Ass'y—Pistol Handle Complete
43464	Ass'y—Lever Handle Complete
53193	Ass'y—Offset Handle Complete (Right Hand Rotation)
53208	Ass'y—Offset Handle Complete (Non-Locking Reversing Valve)

**SIoux  
TOOLS INC.**

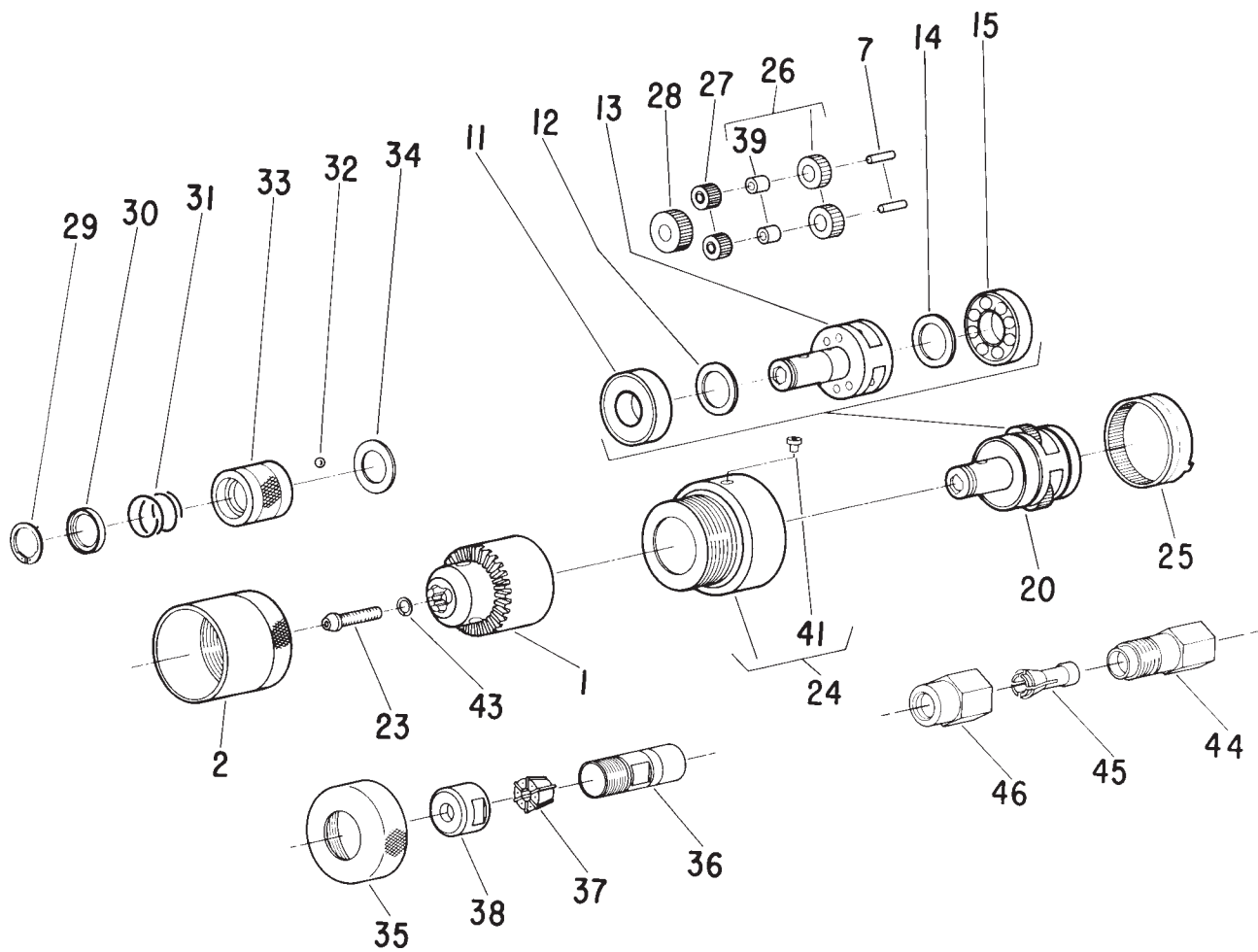

# PARTS LIST FOR SINGLE REDUCTION GEAR CASE 1600, 1900, 2000, 2500, 4000, & 5200 RPM UNITS

Fig. No.	Part No.	Description	Fig. No.	Part No.	Description
1.	21077	Chuck—1/4" Cap.	26.	19314	Gear-Idler (2)*(1900 & 2500 RPM)
	21084	Chuck—5/16" Cap.	27.	19315	Gear-Idler (2)*(4000 & 5200 RPM)
	30000	Key—Chuck (Use with 21077)		19317	Gear-Idler (2)*(1600 & 2000 RPM)
	30002	Key—Chuck (Use with 21084)	28.	19159	Gear-Pinion (4000 & 5200 RPM)
2.	34952	Shield—Chuck 1/4" Cap.	29.	21501	Ring-Retainer (Stall Drive)
	34951	Shield—Chuck 5/16" Cap.	30.	44660	Ring-Guide (Stall Drive)
7.	30062	Pin (2)*	31.	21406	Spring (Stall Drive)
11.	10221	Bearing—Ball	32.	10902	Ball-Steel (Stall Drive)
	10228	Bearing—Ball (Stall Drive and Clinch Nut)	33.	44161	Retainer-Ball (Stall Drive)
12.	25987	Washer	34.	25439	Washer (Stall Drive)
	25439	Washer (Stall Drive and Clinch Nut)	35.	44171	Ring-Grip
13.	64165	Spindle—Tool (Screwdriver & Nutrunner) (1900-2500 RPM)	36.	21086	Ass'y-Collet Chuck & Nut (Includes Fig. 38) (Up to Serial "L")
	64166	Spindle—Tool (Screwdriver) (4000 & 5200 RPM)		30445	Wrench-1/2", Open End (Up to Serial "L")
	22662	Spindle—Tool (Screwdriver & Nutrunner) (1600 & 2000 RPM)		30446	Wrench-5/8", Open End (Up to Serial "L")
	64167	Spindle—Chuck (Drill)(1900 & 2500 RPM)	37.	21087	Collet .198"-.250" (Up to Serial "L")
	64168	Spindle—Chuck (Drill)(4000 & 5200 RPM)		21088	Collet .146"-.198" (Up to Serial "L")
	22663	Spindle—Chuck (Drill)(1600-2000 RPM)		21089	Collet .094"-.146" (Up to Serial "L")
	64157	Spindle—Tool (Stall Drive & Clinch Nut) (1900, 2500 RPM)	38.	21093	Nut-Collet (Up to Serial "L")
	64150	Spindle—Tool (Stall Drive & Clinch Nut) (4000 5200 RPM)	39.	10040	Bearing-Needle
	22664	Spindle—Tool (Stall Drive & Clinch Nut) (1600 & 2000 RPM)	41.	30375	Fitting-Grease
14.	25439	Washer	43.	09712	Washer-Lock 5/16"
15.	10203	Bearing—Ball	44.	21096	Body-Collet (Serial "L")
20.	33622	Ass'y—Planetary Gear (Screwdriver & Nutrunner)(1900-2500 RPM)	45.	44440	Collet-1/4" (Serial "L")
	43742	Ass'y—Planetary Gear (Screwdriver & Nutrunner)(1600 & 2000 RPM)		44523	Collet-3/16" (Serial "L")
	33623	Ass'y—Planetary Gear (Screwdriver) (4000 & 5200 RPM)		44522	Collet-1/8" (Serial "L")
	33617	Ass'y—Planetary Gear (Drill-1600 & 2000 RPM)	46.	21097	Nut-Collet (Serial "L")
	33649	Ass'y—Planetary Gear (Drill-4000 & 5200 RPM)		30465	Wrench-9/16" Open End (Serial "L")
	63380	Ass'y—Planetary Gear (Stall Drive only) (1900 & 2500 RPM)(Includes Figs. 29-34)		30466	Wrench-11/16" Open End (Serial "L")
	43744	Ass'y—Planetary Gear (Stall Drive only) (1600 & 2000 RPM)(Includes Figs. 29-34)	COMPLETE ASSEMBLY		
	43115	Ass'y—Planetary Gear (Stall Drive) (4000 & 5200 RPM)	53308	Ass'y-Gear Case Complete (Drill—4000-5200 RPM)	
	63136	Ass'y—Planetary Gear (Clinch Nut) (1600 RPM)	53307	Ass'y-Gear Case Complete (Drill—1900-2500 RPM)	
	63381	Ass'y—Planetary Gear (Clinch Nut) (1900 RPM)	53320	Ass'y-Gear Case Complete (Drill—1600 & 2000 RPM)	
23.	06602	Screw	53304	Ass'y—Gear Case Complete (Screw Driver & Nut Runner—1900-2500 RPM)	
24.	54419	Case-Gear	53318	Ass'y—Gear Case Complete (Screw Driver & Nut Runner—1600 & 2000 RPM)	
	54422	Case-Gear (Stall Drive Only)	53314	Ass'y—Gear Case Complete (Screw Driver—1900-2500 RPM)(Stall Drive)	
	54780	Case-Gear (Clinch Nut)	53319	Ass'y—Gear Case Complete (Screw Driver—1600 & 2000 RPM)(Stall Drive)	
25.	19160	Gear-Ring	53317	Ass'y—Gear Case Complete (Screw Driver—4000-5200 RPM)(Stall Drive)	
			63146	Ass'y—Gear Case Complete (Clinch Nut)(1900 RPM)	
			63148	Ass'y-Gear Case Complete (Clinch Nut)(1600 RPM)	

\*Order Quantity As Required

**FURNISH CATALOG, SERIAL, AND MODEL NUMBER WHEN  
ORDERING PARTS**

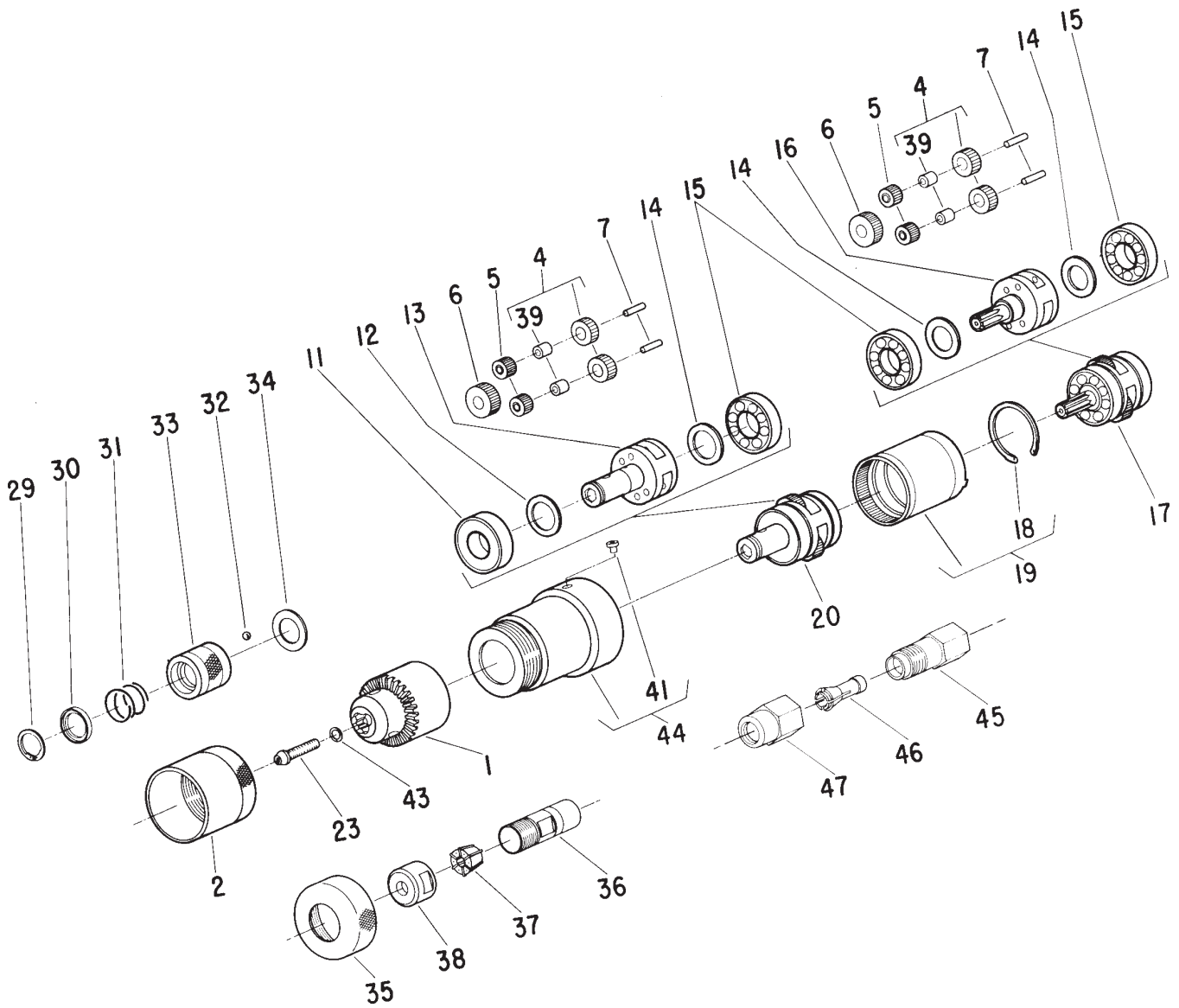

# PARTS LIST FOR DOUBLE REDUCTION GEAR CASE 350, 450, 650, 850, 1300, & 1700 RPM UNITS

Fig. No.	Part No.	Description	Fig. No.	Part No.	Description
1.	21077	Chuck—1/4" Cap. (Drill-All Speeds)	29.	21501	Ring—Retainer (Stall Drive)
	21084	Chuck—5/16" Cap. (Drill-All Speeds)	30.	44660	Ring—Guide (Stall Drive)
	21116	Chuck—3/8" Cap. (Drill)(350 to 850 RPM)	31.	21406	Spring (Stall Drive)
	30000	Key—Chuck (Use with 21077)	32.	10902	Ball—Steel (Stall Drive)
	30002	Key—Chuck (Use with 21084 & 21116)	33.	44161	Retainer—Ball (Stall Drive)
	30231	Key—Chuck (Use with Jacobs No. 2B)	34.	25439	Washer (Stall Drive)
2.	34952	Shield—Chuck 1/4" Cap.	35.	44171	Ring—Grip
	34951	Chuck—5/16" Cap. and Jacobs 3/8" No. 31BA	36.	21086	Ass'y—Collet Chuck & Nut (Includes Fig. 38)(Up to Serial "L")
	44078	Shield—Chuck 3/8" Cap. For Jacobs No. 2B		30445	Wrench—1/2", Open End (Up to Serial "L")
3.	54420	Case—Gear		30446	Wrench—5/8", Open End (Up to Serial "L")
	54423	Case—Gear (Stall Drive Only)	37.	21087	Collet—.198"-.250" (Serial "L")
4.	19314	Gear—Idler [(4)*(350 & 450 RPM)][(2)*(650 & 850 RPM, 2nd Planetary)]		21088	Collet—.146"-.198" (Serial "L")
5.	19315	Gear—Idler [(2)*(650 & 850 RPM, 1st Planetary)][(4)*(1300 & 1700 RPM)]		21089	Collet—.094"-.146" (Serial "L")
6.	19159	Gear—Pinion [(1)*(650 & 850 RPM, 1st Planetary)][(2)*(1300 & 1700 RPM)]	38.	21093	Nut—Collet (Up to Serial "L")
7.	30062	Pin (4)*	39.	10040	Bearing—Needle
11.	10221	Bearing—Ball	41.	30375	Fitting—Grease
	10228	Bearing—Ball (Stall Drive Only)	43.	09712	Washer—Lock 5/16"
12.	25987	Washer	44.	54420	Case—Gear
	25439	Washer (Stall Drive and Clinch Nut)		54805	Case—Gear (Clinch Nut)
13.	64165	Spindle—Tool (Screw Driver & Nutrunner) (350-850 RPM)		54423	Case—Gear (Stall Drive Only)
	64166	Spindle—Tool (Screw Driver & Nutrunner) (1300-1700 RPM)	45.	21096	Body—Collet (Serial "L")
	64167	Spindle—Chuck (Drill)(350-850 RPM)	46.	44440	Collet—1/4" (Serial "L")
	64168	Spindle—Chuck (Drill)(1300-1700 RPM)		44523	Collet—3/16" (Serial "L")
	64157	Spindle—Tool (Stall Drive & Clinch Nut) (350-850 RPM)		44522	Collet—1/8" (Serial "L")
	64150	Spindle—Tool (Stall Drive & Clinch Nut) (1300-1700 RPM)	47.	21097	Nut—Collet (Serial "L")
14.	25439	Washer (3)*	48.	30465	Wrench—9/16" Open End (Serial "L")
15.	10203	Bearing—Ball (3)*		30466	Wrench—11/16" Open End (Serial "L")
16.	64151	Carrier—Gear (650-1700 RPM)	COMPLETE ASSEMBLY		
	64160	Carrier—Gear(350-450 RPM)		53306	Ass'y—Gear Case Complete (Drill)(1300-1700 RPM)
17.	33621	Assy—First Planetary Gear (650-1700 RPM)		53303	Ass'y—Gear Case Complete (Screwdriver & Nutrunner)(1300-1700 RPM)
	63386	Assy—First Planetary Gear (350-450 RPM)		53305	Ass'y—Gear Case Complete (Drill)(650-850 RPM)
18.	21510	Ring—Retainer		53302	Ass'y—Gear Case Complete (Screwdriver & Nutrunner)(650-850 RPM)
19.	19153	Gear—Ring		53312	Ass'y—Gear Case Complete (Screwdriver)(650-850 RPM)(Stall Drive)
20.	33622	Assy—Planetary Gear (Screw Driver & Nutrunner)(350-850 RPM)		53313	Ass'y—Gear Case Complete (Screwdriver)(1300-1700 RPM)(Stall Drive)
	33617	Ass'y—Planetary Gear (Drill)(350-850 RPM)		53311	Ass'y—Gear Case Complete (Screwdriver & Nutrunner)(350-450 RPM)
	33623	Assy—Planetary Gear (Screw Driver & Nutrunner)(1300-1700 RPM)		53310	Ass'y—Gear Case Complete (Drill)(350-450 RPM)
	33649	Ass'y—Planetary Gear (Drill)(1300-1700 RPM)		53315	Ass'y—Gear Case Complete (Screwdriver)(350-450 RPM)(Stall Drive)
	63380	Ass'y—Planetary Gear (Stall Drive Only) (350-850 RPM)(Includes Figs. 29-34)		63144	Ass'y—Gear Case Complete (Clinch Nut)(650 RPM)
	43115	Ass'y—Planetary Gear (Stall Drive Only) (1300 & 1700 RPM)(Includes Figs. 29-34)		63145	Ass'y—Gear Case Complete (Clinch Nut)(1300 RPM)
	63381	Ass'y—Planetary Gear (Clinch Nut)(350 & 850 RPM)		63147	Ass'y—Gear Case Complete (Clinch Nut)(350 RPM)
	63134	Ass'y—Planetary Gear (Clinch Nut)(1300 RPM)			
23.	06500	Screw—3/8"			
	06602	Screw—1/4" & 5/16"			

\*Order Quantity As Required

**FURNISH CATALOG, SERIAL, AND MODEL NUMBER WHEN  
ORDERING PARTS**

# PARTS LIST FOR AIR MOTORS DIRECT & POSITIVE CLUTCH

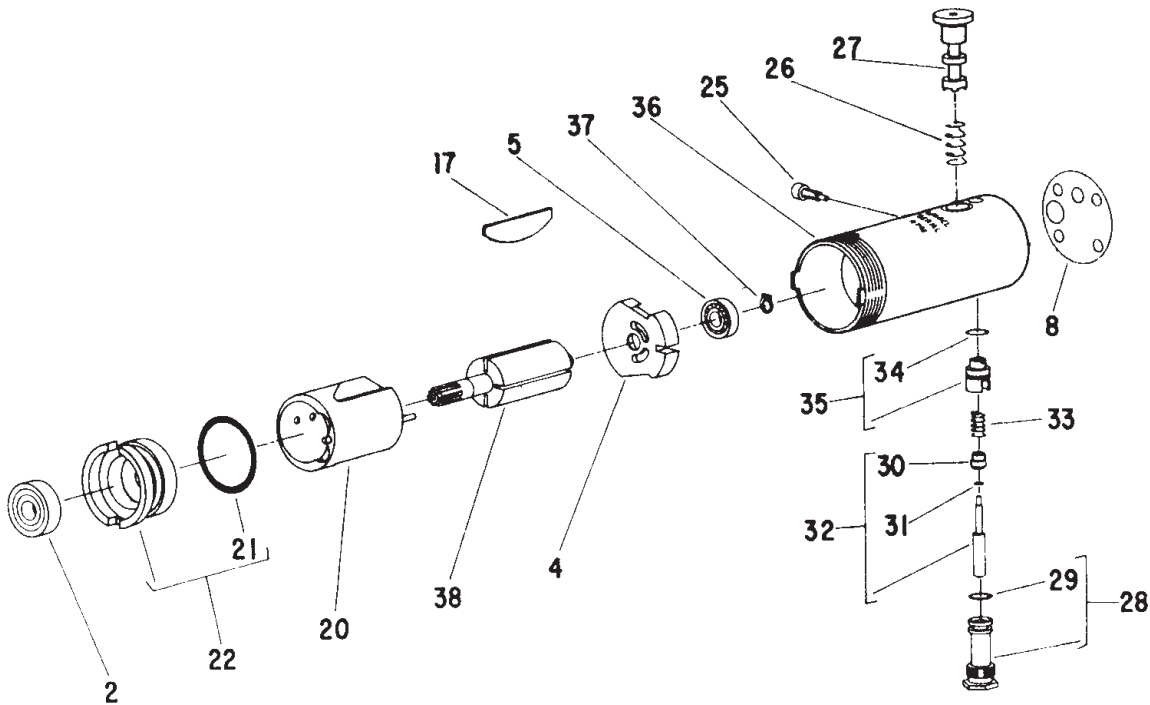

Fig. No.	Part No.	Description
2.	10220	Bearing—Ball
4.	13161	Plate—Upper End
5.	10230	Bearing—Ball
8.	*14734	Gasket
17.	33737	Vane—Rotor (Set of 4)
20.	33738	Ass'y—Cylinder (Reversing)
	33740	Ass'y—Cylinder (Single Rotation, Right Hand)
21.	14342	Ring—"O"
22.	33741	Ass'y—Lower End Plate
25.	*06502	Screw—Retaining
26.	21427	Spring
27.	44426	Spool—Valve (Reversing Only)(Non-Locking)
	44316	Spool—Valve (Reversing Only)(Locking)
28.	*43508	Ass'y—Valve Seat & "O" Ring
29.	*14291	Ring—"O"
30.	*14350	Valve
31.	*25957	Washer
32.	*43462	Ass'y—Valve
33.	*21429	Spring
34.	*14394	Ring—"O"
35.	*43457	Ass'y—Speed Control "O" Ring
36.	*43456	Housing (Reversing)
	*44666	Housing (Single Rotation, Right Hand)
37.	21491	Ring—Retaining

Fig. No.	Part No.	Description
38.	44511	Rotor (Reversing)
	44513	Rotor (Single Rotation, Right Hand)
	44903	Rotor (Reversing)(1600 RPM Only)
	44904	Rotor (Single Rotation)(2000 RPM Only)

## COMPLETE ASSEMBLY

*43459	Ass'y—Reversing Motor Complete
*43737	Ass'y—Reversing Motor Complete (1600 RPM Only)
*43458	Ass'y—Right Rotation Motor Complete
*43738	Ass'y—Right Rotation Motor Complete (2000 RPM Only)
43091	Ass'y—Reversing Motor Complete (Offset Handle)
43739	Ass'y—Reversing Motor Complete (Offset Handle)(1600 RPM Only)
43103	Ass'y—Right Rotation Motor Complete (Offset Handle)
43740	Ass'y—Right Rotation Motor Complete (Offset Handle)(2000 RPM Only)

\* Used with P & L Type Handles Only

FURNISH CATALOG, SERIAL, AND MODEL NUMBER WHEN ORDERING PARTS

# PARTS LIST FOR DIRECT & POSITIVE CLUTCH

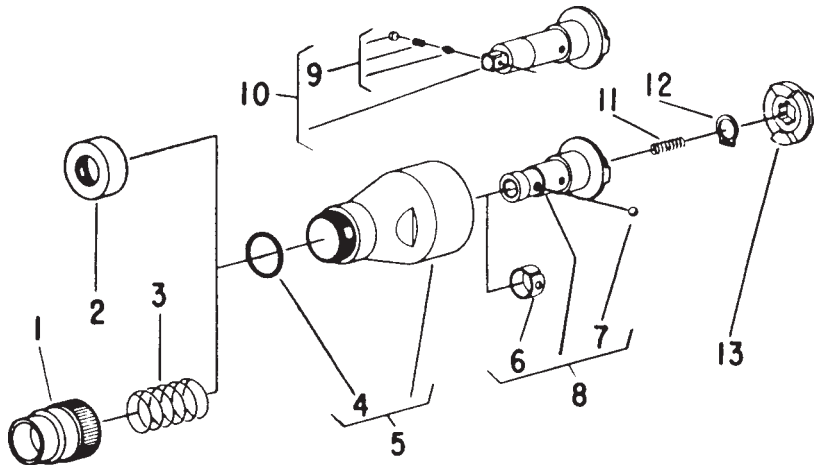

**DIRECT CLUTCH**

**POSITIVE CLUTCH**

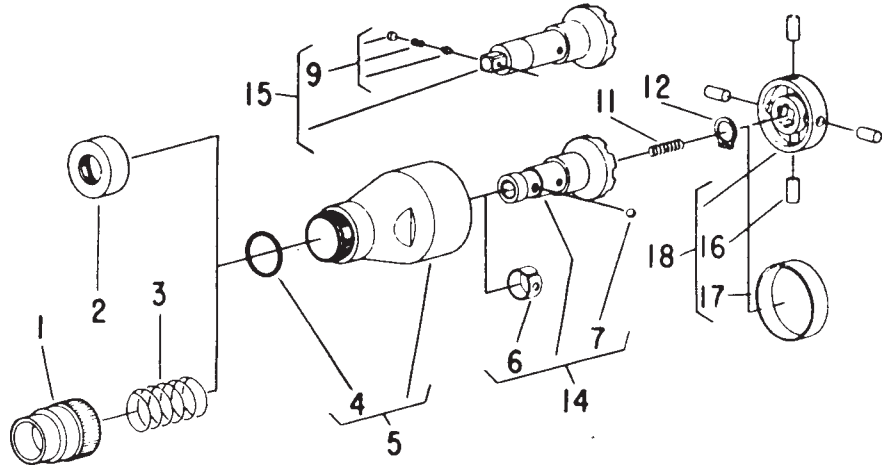

Fig. No.	Part No.	Description
1.	44520	Retainer—Finder (Screwdriver)
2.	54076	Protector—Thread
3.	41251	Spring—Finder (Screwdriver)
4.	14281	Ring—"O"
5.	53100	Ass'y—Clutch & "O" Ring
6.	25854	Ring—Ball Retainer
7.	10902	Ball—Retainer
8.	33632	Socket—Driver (Screwdriver)
9.	33465	Ass'y—Socket Retainer (3/8" Sq. Nutrunner)
	33827	Ass'y—Socket Retainer (1/4" Sq. Nutrunner)
10.	53151	Ass'y—Drive Spindle (3/8" Sq. Nutrunner)
	53153	Ass'y—Drive Spindle (1/4" Sq. Nutrunner)
11.	21379	Spring
12.	21500	Ring—Retainer
13.	34933	Clutch—Upper
14.	33631	Socket—Drive (Screwdriver)
15.	53152	Ass'y—Drive Spindle (3/8" Sq Nutrunner)
	53154	Ass'y—Drive Spindle (1/4" Sq. Nutrunner)
16.	34856	Roller (4)*

Fig. No.	Part No.	Description
17.	34854	Ring—Roller Retainer
18.	33630	Ass'y—Roller Cage

**COMPLETE ASSEMBLY**

53117	Ass'y—Direct Clutch Complete (Screwdriver)
53113	Ass'y—Direct Clutch Complete (1/4" Sq. Nutrunner)
53115	Ass'y—Direct Clutch Complete (3/8" Sq. Nutrunner)
53118	Ass'y—Positive Clutch Complete (Screwdriver)
53116	Ass'y—Positive Clutch Complete (1/4" Sq. Nutrunner)
53114	Ass'y—Positive Clutch Complete (3/8" Sq. Nutrunner)

\*Order Quantity As Required

FURNISH CATALOG, SERIAL, AND MODEL NUMBER WHEN ORDERING PARTS

# PARTS LIST FOR ADJUSTABLE CLUTCH

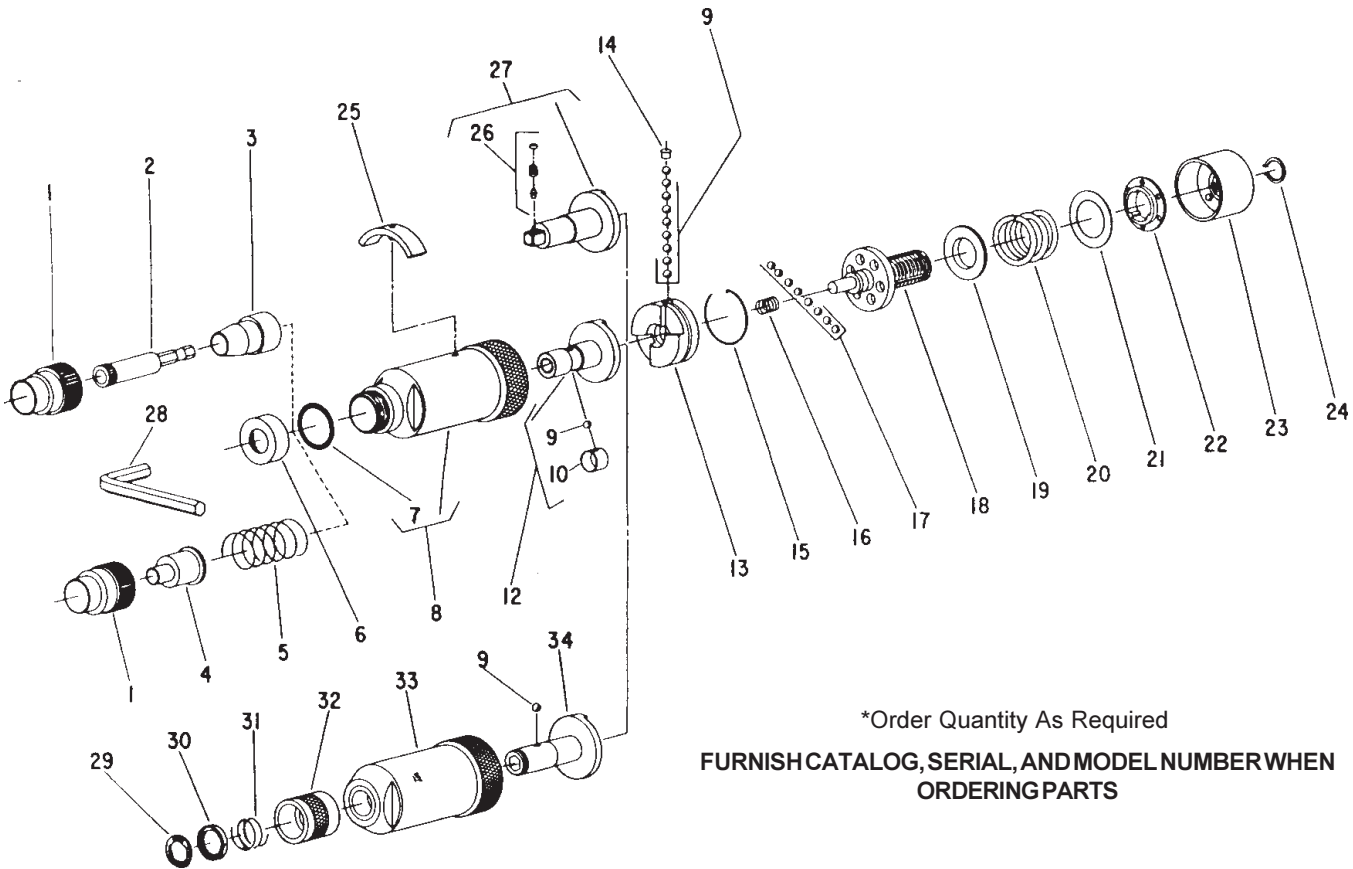

\*Order Quantity As Required

FURNISH CATALOG, SERIAL, AND MODEL NUMBER WHEN ORDERING PARTS

Fig. No.	Part No.	Description
1.	44520	Retainer-Finder
2.	2525	Bit Holder-Magnetic (Mag. Only)
3.	2497	Bushing (Mag. Only)
4.	2766	Finder (Use with Bit 2748)
	2767	Finder (Use with Bit 2749)
	2768	Finder (Use with Bit 2736)
	2769	Finder (Use with Bit 2738)
	2774	Finder (Use with Bit 2732)
	2775	Finder (Use with Bit 2779)
	2776	Finder (Use with Bit 2781)
	2777	Finder (Use with Bit 2742)
	2778	Finder (Use with Bit 2750)
5.	41251	Spring-Finder
6.	54076	Protector-Thread
7.	14281	Ring-"O"
8.	53074	Ass'y-Clutch Case
9.	10902	Ball-Steel (10)*
10.	25854	Clip-Retainer
12.	53076	Ass'y-Bit Holder
13.	54071	Jaw-Clutch
14.	54074	Retainer-Ball
15.	21762	Ring-Retaining (Includes Wire & Spiral)
16.	41250	Spring
17.	10291	Ball-Steel (8)*
18.	22669	Spindle-Clutch
19.	54072	Guide-Spring
20.	41249	Spring-Compression (For torque settings above 25 inch pounds)
	41284	Spring-Compression (Green)(For torque settings below 25 inch pounds)

Fig. No.	Part No.	Description
21.	35273	Washer
22.	54073	Washer-Index
23.	53095	Nut-Adjusting
24.	21774	Ring-Retaining
25.	53099	Wrench-Adjusting
26.	33827	Ass'y-Socket Retainer (1/4" Sq. Nutrunner)
	33465	Ass'y-Socket Retainer (3/8" Sq. Nutrunner)
27.	53082	Spindle-Drive (1/4" Sq. Nutrunner)
	53083	Spindle-Drive (3/8" Sq. Nutrunner)
28.	30208	Wrench-Alien
29.	21501	Ring-Retaining
30.	44660	Ring-Guide
31.	21406	Spring
32.	54468	Retainer-Ball
33.	54470	Case-Clutch
34.	22677	Holder-Bit

## COMPLETE ASSEMBLY

53090	Ass'y-Adjustable Clutch Complete (1/4" Hex. Screwdriver)
53089	Ass'y-Adjustable Clutch Complete (3/8" Sq. Nutrunner)
53088	Ass'y-Adjustable Clutch Complete (1/4" Sq. Nutrunner)
53586	Ass'y-Clutch Case & Bit Holder (Quick Change Screwdriver) (Incl. Fig's. 9, 29 thru 34)

# PARTS LIST FOR POSITIVE ANGLE JAW CLUTCH TYPE "A"

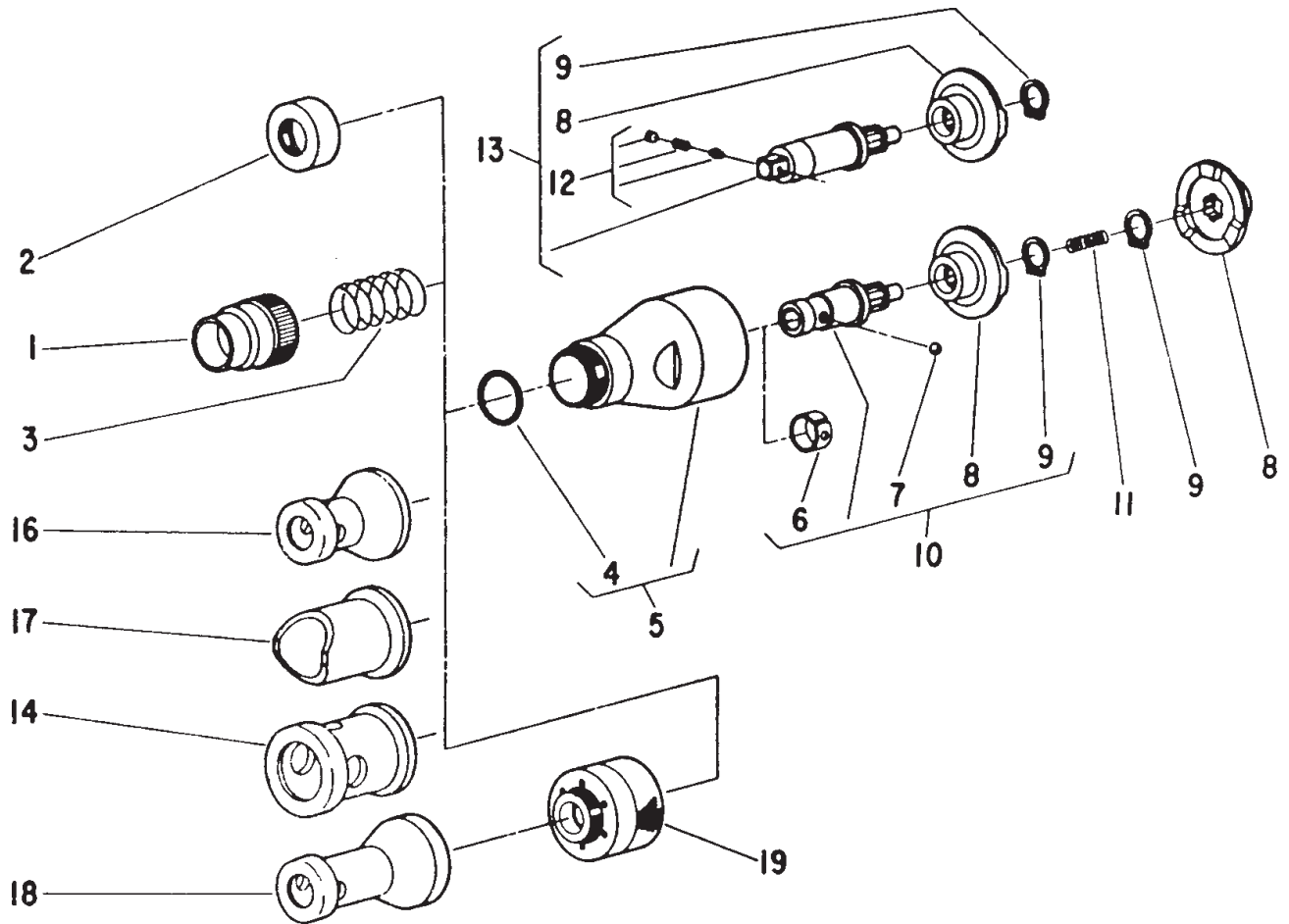

Fig. No.	Part No.	Description
1.	44520	Retainer—Finder (Screwdriver)
2.	54076	Protector—Thread (Except "DF")
	54862	Adapter ("DF" Only)
3.	41251	Spring—Finder (Screwdriver)
4.	14281	Ring—"O"
5.	53100	Ass'y—Clutch Case & "O" Ring
6.	25854	Ring—Ball Retainer (Screwdriver)
7.	10902	Ball—Retainer (Screwdriver)
8.	44662	Jaw—Clutch (2)*
9.	21500	Ring—Retaining (2)*
10.	43452	Ass'y—Drive Socket (Screwdriver)
11.	21379	Spring
12.	33465	Ass'y—Socket Retainer (3/8" Sq. Nut Runner)
	33827	Ass'y—Socket Retainer (1/4" Sq. Nutrunner)
13.	53156	Ass'y—Drive Spindle (3/8" Sq. Nutrunner)
	53155	Ass'y—Drive Spindle (1/4" Sq. Nutrunner)
		(Incl. (1) each of Fig. 8 & 9)
14.	54104	Nose Piece—Fastener Locator (Std.)
	14110	Cap—End

Fig. No.	Part No.	Description
16.	54103	Nose Piece—Round Locator
	14109	Cap—End
17.	53510	Ass'y—Straddle Nose Piece
18.	54241	Nose Piece—Long Round Locator
	14109	Cap—End
19.	53511	Ass'y—Depth Locator Base
		(Use with Figs. 14, 16 or 17)
	53512	Ass'y—Depth Locator Base (Use with Fig. 18)

### COMPLETE CLUTCH ASSEMBLY

53136	Ass'y—Positive Angle Jaw Clutch (Screwdriver)(Less Figs.14 thru 19)
53137	Ass'y—Positive Angle Jaw Clutch (1/4" Sq. Nutrunner)(Less Figs.14 thru 19)
53138	Ass'y—Positive Angle Jaw Clutch (3/8" Sq. Nutrunner)(Less Figs.14 thru 19)

\*Order Quantity As Required

**FURNISH CATALOG, SERIAL, AND MODEL NUMBER WHEN  
ORDERING PARTS**

# PARTS LIST FOR ALL ANGLE HEAD

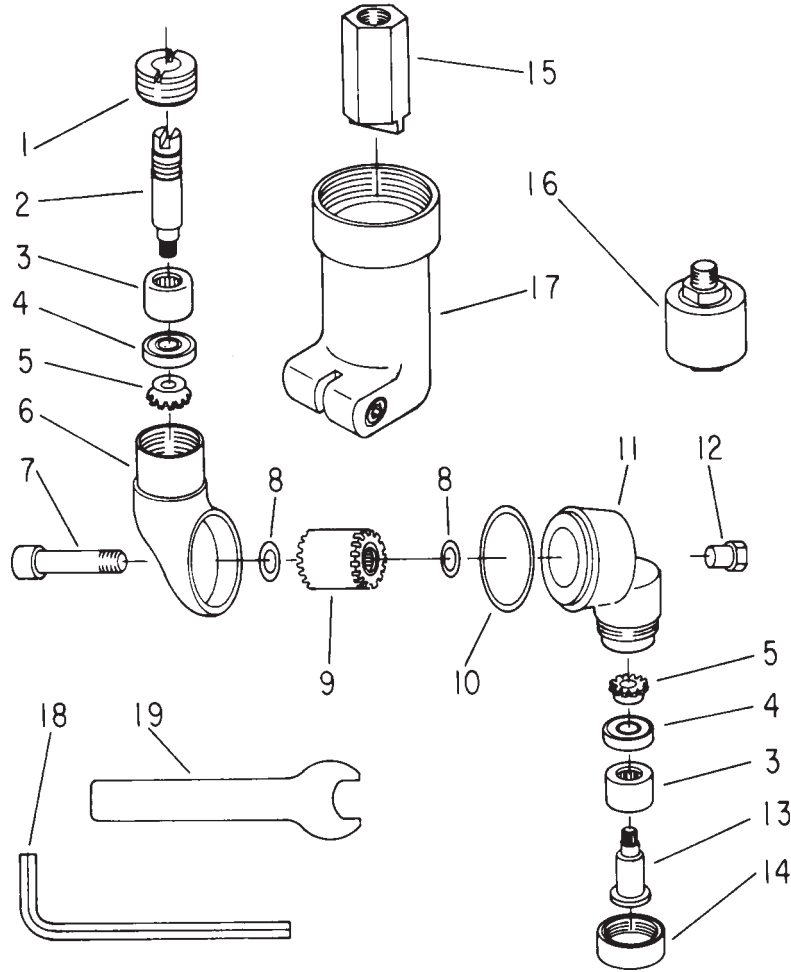
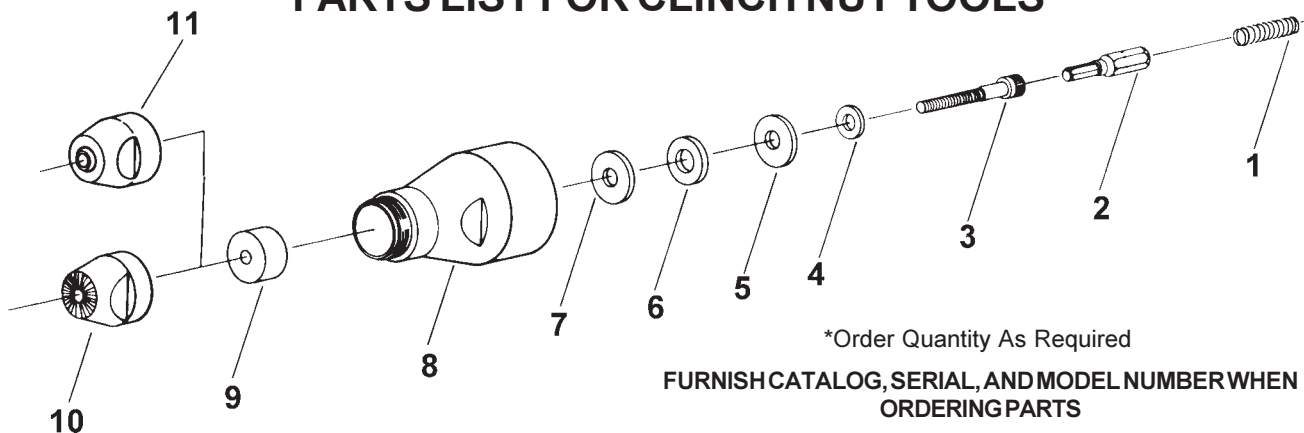

Fig. No.	Part No.	Description
1.	13308	Nut—Rear Bearing Retainer
2.	54641	Drive—Spindle
3.	10068	Bearing—Needle
4.	10285	Bearing—Ball
5.	19473	Gear—Pinion
6.	12403	Housing—Drive Spindle
7.	40004	Stud—Swivel
8.	35449	Washer—Shim (.010")
9.	19330	Ass'y—Gear & Bearings
10.	40006	Washer—Copper Shim
11.	12404	Housing—Drill Spindle
12.	40005	Nut—Swivel Stud
13.	54642	Spindle—Drill
14.	54643	Retainer—Front Bearing
15.	54616	Coupler
16.	21130	Chuck—Complete
17.	12401	Sleeve
18.	30206	Wrench—Allen (3/16")
19.	40007	Wrench—Chuck Body
	53822	Ass'y—All Angle Head (Includes Figs. 1 thru 14, and 16, 19)

\*Order Quantity As Required

FURNISH CATALOG, SERIAL, AND MODEL NUMBER WHEN ORDERING PARTS

# PARTS LIST FOR CLINCH NUT TOOLS



\*Order Quantity As Required

FURNISH CATALOG, SERIAL, AND MODEL NUMBER WHEN ORDERING PARTS

Fig. No.	Part No.	Description
1.	21411	Spring
2.	54907	Bit—Insert (#4)
	54908	Bit—Insert (M3)
	36820	Bit—Insert (#6)
	36821	Bit—Insert (M4)
	2952	Bit—Insert (#8)
	2536	Bit—Insert (#10)
	36822	Bit—Insert (M5)
	36823	Bit—Insert (M6)
	2567	Bit—Insert (1/4")
	54827	Bit—Insert (5/16")
	54910	Bit—Insert (M8)
	54909	Bit—Insert (3/8")
3.	06086	Screw—Soc. Hd. Cap (#4-40 x 1")
	56101	Screw—Soc. Hd. Cap (M3 x 0.5 x 25mm)
	06211	Screw—Soc. Hd. Cap (#6-32 x 1-1/2")
	56203	Screw—Soc. Hd. Cap (M4 x 0.7 x 40mm)
	06603	Screw—Soc. Hd. Cap (#8-32 x 1-1/2")
	07085	Screw—Soc. Hd. Cap (#10-32 x 1-1/2")
	57001	Screw—Soc. Hd. Cap (M5 x 0.8 x 40mm)
	57551	Screw—Soc. Hd. Cap (M6 x 1.0 x 50mm)
	08302	Screw—Soc. Hd. Cap (1/4"-20 x 2")
	08796	Screw—Soc. Hd. Cap (5/16"-18 x 2-3/8")
	58551	Screw—Soc. Hd. Cap (M8 x 1.25 x 60mm)
	09085	Screw—Soc. Hd. Cap (3/8"-16 x 2-3/8")
4.	54903	Washer (#4, M3)
	54904	Washer (#6)
	25196	Washer (M4, #8)
	35234	Washer (#10, M5)
	41340	Washer (1/4")(Crown Side Toward Screw Head)
	54825	Washer (5/16", M8)
5.	10077	Washer—Thrust (#4, M3, #6, M4, #8, M6, 1/4")
	67155	Washer—Thrust (#10, M5)(Smaller ID than Fig. 7)
	10079	Washer—Thrust (5/16", M8, 3/8")
6.	10072	Bearing—Thrust (#4, M3, #6, M4, #8, #10, M5, M6, 1/4")
	10078	Bearing—Thrust (5/16", M8, 3/8")
7.	10077	Washer—Thrust (#4, M3, #6, M4, #8, #10, M5, M6, 1/4")
	10079	Washer—Thrust (5/16", M8, 3/8")
8.	54108	Case—Clutch (#4, M3, #6, M4, #8, #10, M5, M6, 1/4")
	54826	Case—Clutch (5/16", M8, 3/8")
9.	54905	Spacer (#6, M4, #8)
	54906	Spacer (5/16", M8, 3/8")

Fig. No.	Part No.	Description
10.	54896	Nosepiece (#4, M3)
	54897	Nosepiece (#6)
	54898	Nosepiece (M4, #8)
	54899	Nosepiece (#10, M5)
	54900	Nosepiece (M6, 1/4")
	54901	Nosepiece (5/16", M8)
	54902	Nosepiece (3/8")
11.	64211	Nosepiece (#10) "T" Series
	64180	Nosepiece (1/4") "T" Series
	64181	Nosepiece (5/16") "T" Series
	64182	Nosepiece (3/8") "T" Series

## COMPLETE ASSEMBLY

63287	Ass'y—Installer Head (#4)
63286	Ass'y—Installer Head (M3)
63288	Ass'y—Installer Head (#6)
63289	Ass'y—Installer Head (M4)
63137	Ass'y—Installer Head (#8)
63138	Ass'y—Installer Head (#10)
63290	Ass'y—Installer Head (M5)
63291	Ass'y—Installer Head (M6)
63139	Ass'y—Installer Head (1/4")
63140	Ass'y—Installer Head (5/16")
63292	Ass'y—Installer Head (M8)
63293	Ass'y—Installer Head (3/8")
63594	Ass'y—Installer Head (#10) "T" Series
63586	Ass'y—Installer Head (1/4") "T" Series
63587	Ass'y—Installer Head (5/16") "T" Series
63588	Ass'y—Installer Head (3/8") "T" Series

## CONVERSIONS KITS

63295	Conversion Kit #4 (Includes Figs. 2-7, 10)
63294	Conversion Kit M3 (Includes Figs. 2-7, 10)
63296	Conversion Kit #6 (Includes Figs. 2-7, 9, 10)
63298	Conversion Kit M4 (Includes Figs. 2-7, 9, 10)
63297	Conversion Kit #8 (Includes Figs. 2-7, 9, 10)
63299	Conversion Kit #10 (Includes Figs. 2-7, 9, 10)
63300	Conversion Kit M5 (Includes Figs. 2-7, 9, 10)
63302	Conversion Kit M6 (Includes Figs. 2, 3, 5-7, 10)
63301	Conversion Kit 1/4" (Includes Figs. 2-7, 10)
63303	Conversion Kit 5/16" (Includes Figs. 2-7, 9, 10)
63304	Conversion Kit M8 (Includes Figs. 2-7, 9, 10)
63305	Conversion Kit 3/8" (Includes Figs. 2, 3, 5-7, 9, 10)

NOTE: Also check figure 8 to see if your conversion requires a different clutch case.



**SIoux  
TOOLS INC.**

250 SNAP-ON DRIVE ■ PO BOX 1596 ■ MURPHY, NC 28906 ■ USA ■

Printed In U.S.A.