

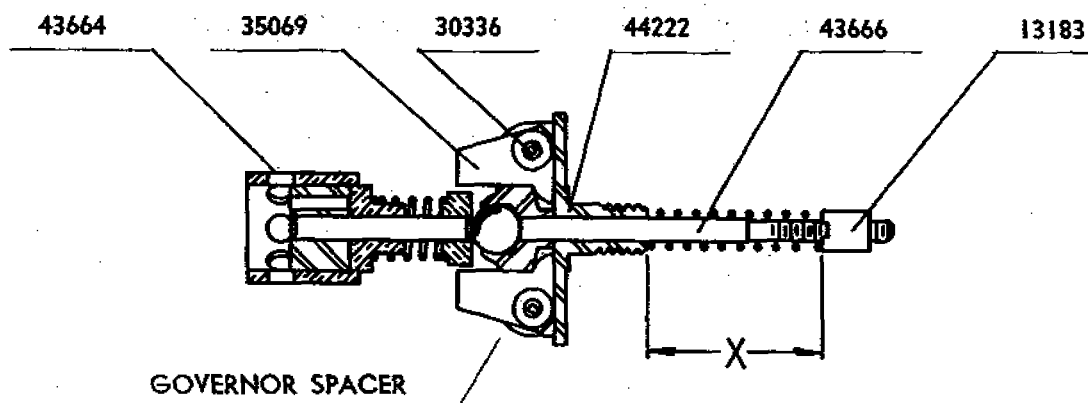

# BALL GOVERNORS FOR SMALL GRINDERS AND AIR DRILLS



## INSTRUCTIONS

Remove governor (left hand thread) and governor valve. Oil new governor valve and governor stem. Reassemble governor valve and governor. Do not overtighten and crack governor frame. Tighten to 6 ft. lbs. torque. Grease the ball and all moving parts with a generous amount of grease. Be certain parts are working freely and correct parts are used.

**CHECK THE SPEED OF THE ASSEMBLED TOOL and readjust spring if necessary. DO NOT OPERATE A GRINDER AT GREATER THAN NAME PLATE SPEED AND GREATER THAN THE SPEED MARKED ON THE GRINDING WHEEL USED.** Such operation can cause injury or death.

Old Governor	Replace with Governor listed and 43664	"X"	Spring No. & Color	Wts per Side	Governor Spacer
33971	43669	5½ #	21411 Red	3	44218
33990	43670	29/32	21416 Green	3	44218
43083	43671	61/64	21411 Red	6	44323
43143	43672	29/32	21411 Red	2	44379

**SIoux TOOLS INC.**  
SIoux CITY, IOWA, U.S.A. 51102